Table of Contents

New Generation 6-cylinder N52

Subject	Page
Introduction	4
Power Output	5
BMW 6-Cylinder Engine History	5
M20	5
M30	5
M50	5
M50TU	5
M52	5
M52TU	6
M54/M56	6
Innovative Solutions	7
Technical Data (N52B30)	8
Engine Power Output (N52 3.0 Liter)	9
Engine Designations and Identification	10
Components	11
Crankcase	12
Bedplate	14
Crankshaft	15
Piston and Connecting Rod	15
Cylinder Head	16
Cylinder Head Cover	16
Valvetrain	17
Camshaft	18
VANOS	18
Intake Manifold	19
Crankcase Ventilation	19
Exhaust Manifold	20
Gaskets/Seals	21
Bolts	22
Oil Pump	23
Electric Water Pump	24
Map Controlled Thermostat	25
Oil-to Water Heat Exchanger (5 Series)	25
Vacuum Pump	26
Alternator	26

Subject	Page
Principle of Operation	36
Magnesium - new material in engine construction	36
Electrochemical Properties of Magnesium	36
Physical Properties of the Materials	37
VALVETRONIC II	38
Load Control	39
Design/Function	40
VANOS	41
Differential Intake Air Control (DISA)	42
Stage 1 - Idle/lower engine speed range	43
Stage 2 - Medium engine speed range	43
Stage 3 - Upper engine speed range	43
DISA Actuators	43
Lubrication System	44
Oil Pump Operation	47
Electronic Oil Condition Monitoring	48
Function of the Oil Condition Sensor	49
Faults/Evaluation	49
Electronic Oil Level Indicator	50
Static oil level measurement at engine OFF	50
Dynamic oil level measurement during vehicle operation	52
Display Options	53
Cooling System	54
Heat Management	54
Intelligent Heat Management	55
Cooling System Comparison (Belt Driven vs. Electric Coolant Pump)	56
Workshop Hints	58
Electronically Controlled Coolant Pump	58
Thread Repair	59
Engine Repairs	59
Working Safety	60
Machining (metal cutting) Magnesium	60
Special Measures for Grinding	60
Important Precondition:	61

New Generation 6-cylinder N52

Model: E60, E61, E90, E91

Production: All

OBJECTIVES

After completion of this module you will be able to:

- Understand new generation engine systems and concepts
- Understand the operation of second generation Valvetronic
- Understand service operations regarding magnesium
- Understand basic engine repairs on the N52

Introduction

Beginning with the N62 V-8 engine, BMW has introduced a new generation of engines with advanced concepts. The primary focus of these engines was the use of Valvetronic which has revolutionized valvetrain technology. Following the N62 engine was the new V-12, the N73 in the new 760i/Li.

To round out the new generation engine lineup, it was only natural that the 6-cylinder engines were included. This new 6-cylinder will be referred to as the N52. Initially, this engine will be introduced into the E60, E61 and E90. Later, the N52 will be installed in subsequent model lines as well.



Initially, the N52 will be offered in the 330i and will be designated N52B30. The B30 variant will also be used in the 325i which will be introduced later in 2005. Although both vehicles will have a 3.0 liter engine, the power output will differ between models. The 330i will receive the 255 horsepower version and the 325 engine will have an output of 215 horsepower.

The engines will be differentiated by the suffix designation. The high output version will be designated N52B30 OL and the lower output will be N52B30 UL. The “UL” engine will have no DISA and will have changes in the DME programming and exhaust system.

The design objectives of the N52 include:

- Increased power output and torque
- Reduction of fuel consumption
- Reduction of overall engine weight
- Top position in engine class through efficient dynamics
- Innovations for customer benefit

The simplest way of achieving these objectives is to reduce the weight of the engine. Since the development of the M50 engine, the aim has always been to achieve ever lowering fuel consumption. The additional benefits from these goals of the development process is increased efficiency and improved dynamics.

Compared to the previous generation engines (M54/M56), a further reduction in fuel consumption of 12% and a 10% increase in dynamics have been achieved with the N52. These increases in efficiency allow the N52 to comply with ULEV II standards.

Power Output

The terms “power output per liter” and “power to weight ratio” are used for comparing individual engine designs with each other. The power output per liter indicates the highest effective power output of the engine per liter of displacement (kW/l).

Compared to the M54 at 55kW/l, the power output of the N52 has been further increased to 61.7 kW/l.

The power to weight ratio indicates the construction weight per kW output (kg/kW). The lower the construction weight as a function of power output, the more efficient the power yield. The power to weight ratio of the N52 also set new standards. Compared to the M54 at 1.0kg/kW, the N52 has been further reduced to 0.82kg/kW.

BMW 6-Cylinder Engine History

M20

BMW 6-cylinder engines have undergone a constant optimization process over time starting with the M20. The M20, which used 2-valves per cylinder, also featured a timing belt for the camshaft drive and adjustable valves. Over the years, The M20 was available with carbureted as well as fuel injected versions throughout the 1970's and 80's.

M30

The M30 which also featured 2 valve per cylinder technology and adjustable valvetrain, did not use a timing belt. The M30 was available in larger displacements up to 3.5 liter. The “big six”, which the top engine in the BMW engine lineup, would later be succeeded by the new BMW V-8 engines in 1993.

M50

The successor to the M20, the M50 featured many new innovations when introduced in 1992. The M50 engine technology included 4-valves per cylinder, Dual overhead camshafts and direct stationary ignition (RZV). This engine also used fully sequential injection controlled by DME 3.1 engine management.

M50TU

The M50 was “technically upgraded” with the addition of VANOS in 1993. The new VANOS system allowed for intake camshaft timing changes which improved horsepower and torque curves. The “TU” variant also featured cylinder selective knock control, Hot Film air mass sensing and secondary ignition monitoring.

M52

The M52, which includes many of the features on the M50TU, utilized Siemens engine control. It was introduced in 1996 to comply with OBDII regulations. The M52 also provided a slight increase in horsepower and a large increase in torque over the M50TU.

M52TU

In 1999, the M52 was further refined by the addition of Double VANOS and an electronically controlled throttle. The new “TU” engine also used innovations such as a variable intake runner length, “near engine” catalytic converters and secondary air injection.

The use of aluminum on the M52TU also extended to the crankcase as well. This would pave the way for future improvements in engine materials.

M54/M56

The M54/M56 variants used much of the technology available at that time, however customer and legislative demands would mean that further improvements would be needed.

With these design goals in mind, BMW brought forth the latest engine construction technology. The “new generation 6” innovations include a new composite magnesium/aluminum engine block, Valvetronic II, electric coolant pump, volumetric flow controlled oil pump and a 3-stage intake manifold.

The new construction configuration allows a weight savings of 10kg (22 lbs.) over the previous generation of six cylinder engines.

History Overview

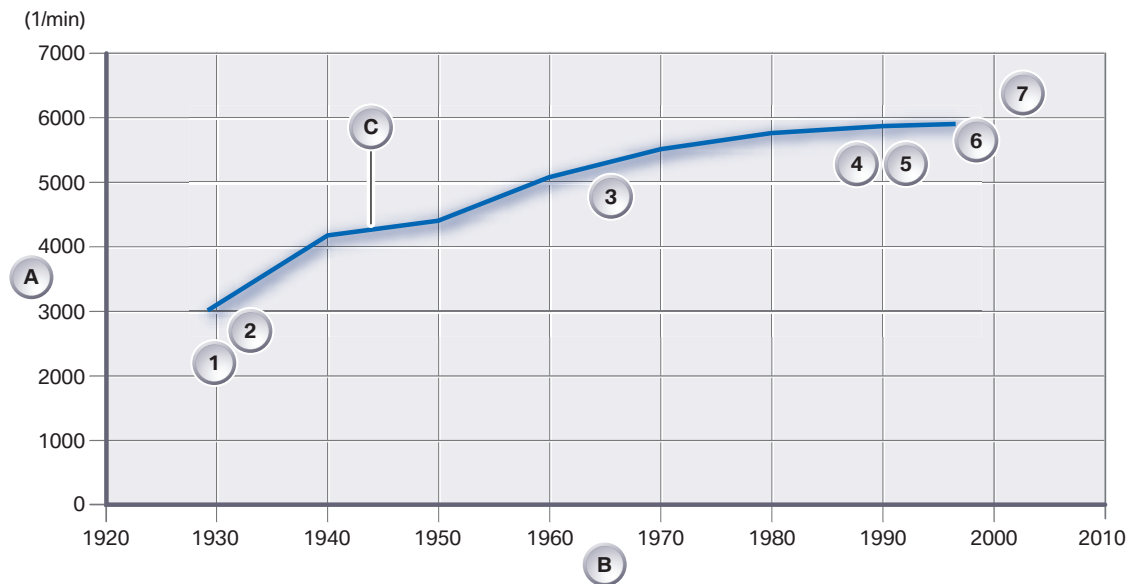

Index	Explanation	Index	Explanation
A	Nominal engine speed	3	2 valves, ohc
B	Year	4	4 valve, dohc
C	Mean values	5	4 valve, dohc, VANOS (single - intake)
1	2 valves, sv	6	4 valve, dohc, VANOS (double E/A)
2	2 valves, ohv	7	4 valve, dohc, VANOS (double) Valvetronic

Innovative Solutions

The N52 engine concept allowed for a substantial weight savings of 10Kg (22lbs.) over its predecessor the M54. The primary contributors to the total weight savings are the new composite magnesium-aluminum crankcase and the lightweight exhaust manifold. Also, the magnesium bedplate and cylinder head cover also played a significant role in overall weight reduction.

The overall lightweight engine package allows for an improved power to weight ratio as well as an improvement in fuel consumption.

The N52 engine also features several innovations designed to further improve the overall engine. Aside from the composite crankcase there is a new Valvetronic II system which has been improved from the original version. The new 3-stage DISA intake manifold is constructed from a high temperature lightweight material. The belt driven coolant pump from previous engines has been replaced by an electric coolant pump. This allows the addition of a single belt drive. There is also a volumetric flow controlled oil pump to supply the required oil for VANOS operation.



Index	Explanation	Index	Explanation
1	Valvetronic II	6	Basic engine, friction reduced
2	Integrated oil-to-water heat exchanger	7	Single belt drive
3	Composite magnesium crankcase	8	Electric coolant pump
4	3-stage intake manifold	9	Weight-optimized VANOS units
5	Volumetric flow controlled oil pump		

Technical Data (N52B30)

Description	Value
Engine Type	6 cylinder in-line
Displacement (cm ³)	2.996
Stroke/bore (mm)	85.0/88.0
Cylinder spacing (mm)	91
Crankshaft main bearing diameter	6 @ 56mm / 1 @ 65mm
Crankshaft big-end (rod) bearing diameter	50mm
Firing Order	1-5-3-6-2-4
Power output (kW/hp)	190/255
@ engine speed	6,600
Torque	300
@ engine speed	2,500 to 4,000
Maximum rpm (governed cutoff)	7,000
Power to weight ratio	0.84
Power output per liter	63.4
Compression ratio	10.7
Valves per cylinder	4
Intake valve diameter (mm)	34.2
Exhaust valve diameter (mm)	29
Minimum intake valve lift (mm)	0.18
Maximum intake valve lift (mm)	9.9
Exhaust valve lift	9.7
Camshaft opening angle, intake (crankshaft degrees)	255
Camshaft opening angle, exhaust (crankshaft degrees)	263
Camshaft spread, intake (crankshaft degrees)	120-50
Camshaft spread, exhaust (crankshaft degrees)	115-60
Engine weight (kg.)	161
Fuel requirement	91 (98 RON)
Engine oil	SAE 5W-30
Knock control	Yes
Intake manifold	3 Stage Resonance Intake Manifold (DISA)
Engine Management	Siemens MSV70
Valvetrain System	Valvetronic II
Emissions Certification	ULEV 2

Engine Power Output (N52 3.0 Liter)

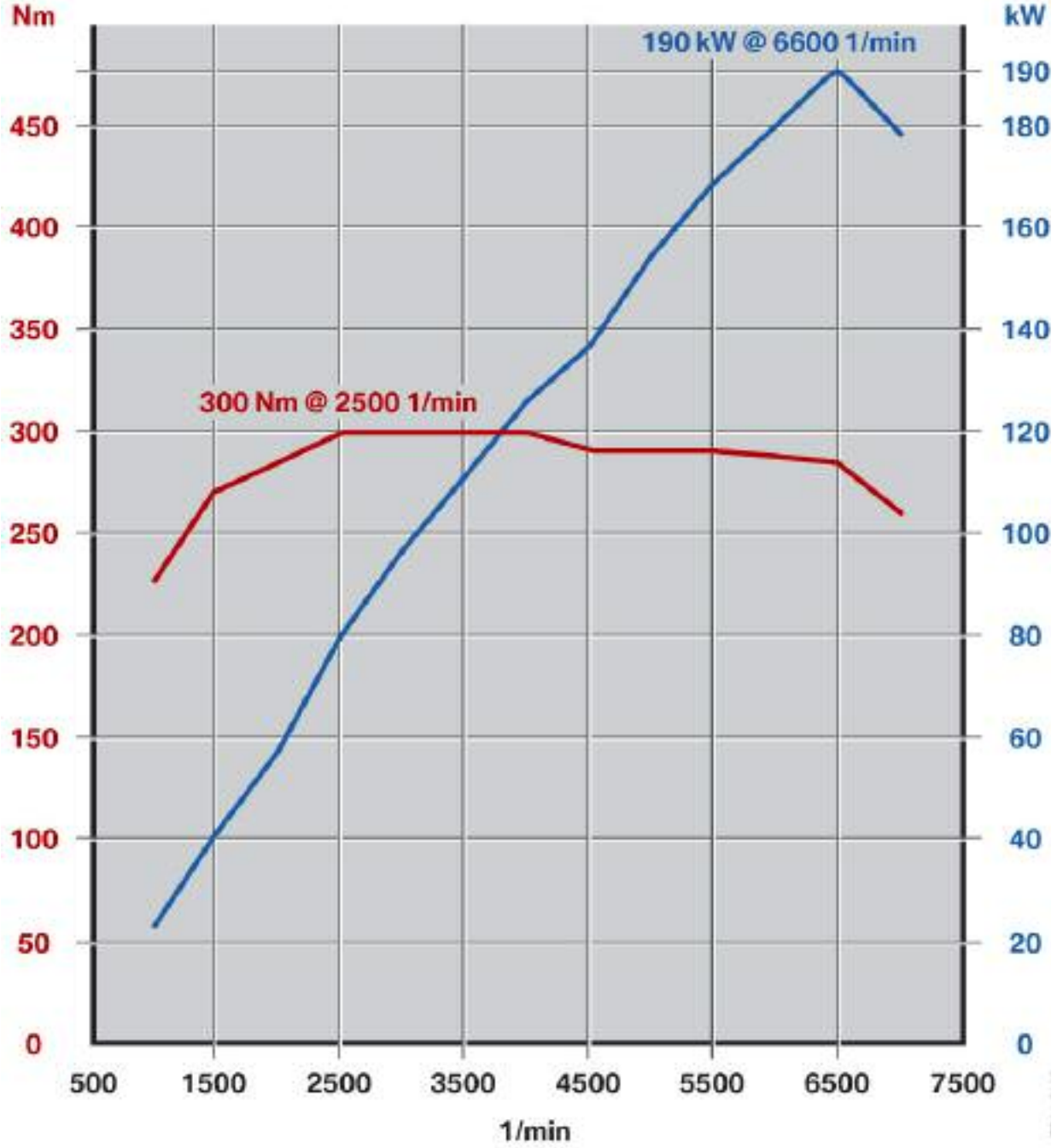

Engine Designations and Identification

The N52 engine uses a similar engine designation to past engines. The new engine designation is broken down as follows:

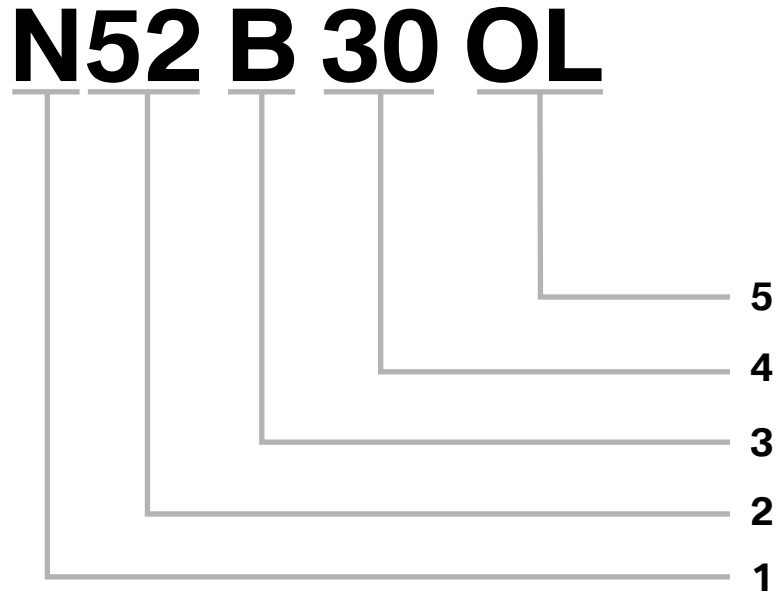

Index	Explanation	Index	Explanation
1	N = New Generation Engine	4	30 = 3.0 Liter Displacement
2	52 = Inline 6 Cylinder Engine	5	OL = Upper Output Stage (High Output)
3	B = Gasoline		

The “OL” designation refers to the upper output stage, the “UL” designation refers to the lower output engine which is not available in the US market. Both, the N52B30 and B25 engine will only be available as the “OL” variant in the US.

The engine identification code is located on the side of the engine block, below the intake manifold directly between the knock sensors. The designation “AF” in the engine code refers to the upper output stage or “OL” variant.

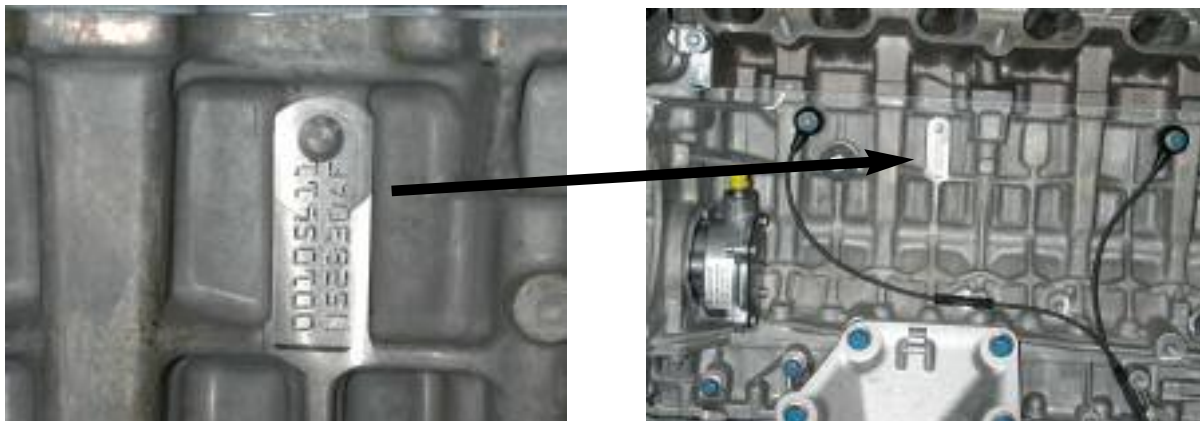

Components

The N52 engine consists of the following components/systems:

- 6-cylinder, 4-valve in-line, friction optimized engine
- Two-piece crankcase in composite magnesium-aluminum structure
- Trapezoidal connecting rods (weight optimized)
- Aluminum silicon (Alusil) cylinder head
- Timing case integrated in crankcase and cylinder head
- Cylinder head gasket with silicon sealing lip
- VALVETRONIC II
- Weight-optimized double VANOS
- Volumetric flow-controlled oil pump
- Electrically controlled coolant pump
- Crankcase ventilation with integrated heater
- 3-stage DISA



Crankcase

Since magnesium cannot be used in all areas of engine construction, the new N52 crankcase is a composite design. The crankcase consists of an aluminum/silicon insert which is cast inseparably in a magnesium alloy.

The crankcase is a two piece design with a separate bedplate also cast from magnesium. Also a notable change from previous designs is the timing cover which is now cast as an integral part of the engine block.

The aluminum silicon insert provides the threaded connections for the transmission mounting, cylinder head and crankshaft main bolts. The insert provides the coolant passages as well. This is to prevent coolant contact with the magnesium portion of the engine block.



The use of magnesium is a new concept for production passenger vehicles. BMW has developed special processes for the development of the N52 crankcase. A special magnesium alloy (AJ62) is used which has excellent properties which reduce the possibility of corrosion and allow favorable machining characteristics.



The cylinder bore consists of an Alusil structure, there are no iron cylinder liners as with previous 6 cylinder designs. The cylinder bores cannot be machined, however this design still allows for planing of the deck surface if needed.



Bedplate

The N52 engine uses a split crankcase, the upper section is made from a composite magnesium/aluminum structure. The lower portion, which is used to increase rigidity, is designed as a bedplate structure made from magnesium.



There are sintered steel inlays (arrow) for the main bearings to take up forces which would not be suitable for magnesium alone.

Between the bedplate and crankcase, a liquid sealer is injected under high pressure into a machined groove. This process is critical in service applications.

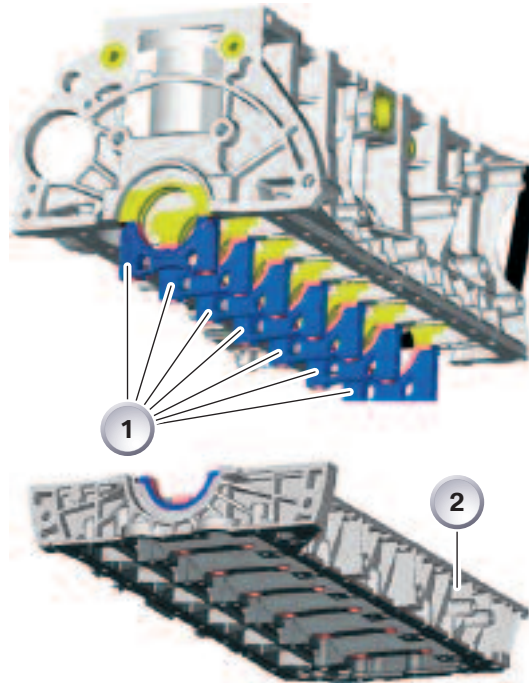

1. Bedplate inlays
2. Bedplate

Crankshaft

The crankshaft is cast iron with 7 main bearing journals. The trigger wheel for the crankshaft position sensor is between cylinders 5 and 6. Due to the design of the timing chain module, the crankshaft snout is modified to facilitate removal during service.



Piston and Connecting Rod

As with previous engine designs, the pistons are manufactured from aluminum and have 4 valve reliefs.

The underside of the pistons are cooled with oil spray jets as in the past.

The connecting rods are weight optimized by tapering the “small end” of the rod. This method reduces weight without reducing strength.

The “big end” of the connecting rod is “cracked” to create to proper centering of the bearing cap without the use of dowel pins. This further contributes to the overall weight reduction. Each connecting rod uses pairing codes (1) to allow the correct rod cap to be matched to the connecting rod.

The connecting rods are divided into weight categories and can only be replaced as a set.

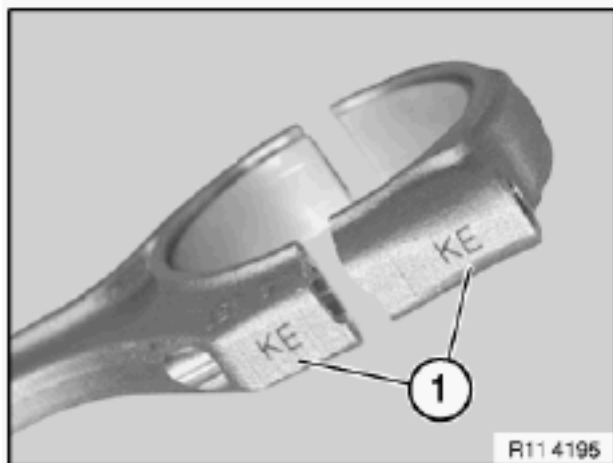

Cylinder Head

The N52 uses an aluminum (AluSil) cylinder head with a cast bridge to mount the VVT actuator motor for the Valvetronic II system.



Cylinder Head Cover

The cylinder head cover is also cast from magnesium alloy as well. The cylinder head cover provides an important mounting point for the VVT motor. The rear of the motor is supported by an aluminum bolt which attaches to a bracket on the cylinder head cover.

All of the bolts which attach the cylinder head cover to the cylinder head are made from aluminum. When performing repairs which involve the removal of the cylinder head cover be sure to replace the bolts and use the the proper torque/angle procedure as outlined in the repair instructions.

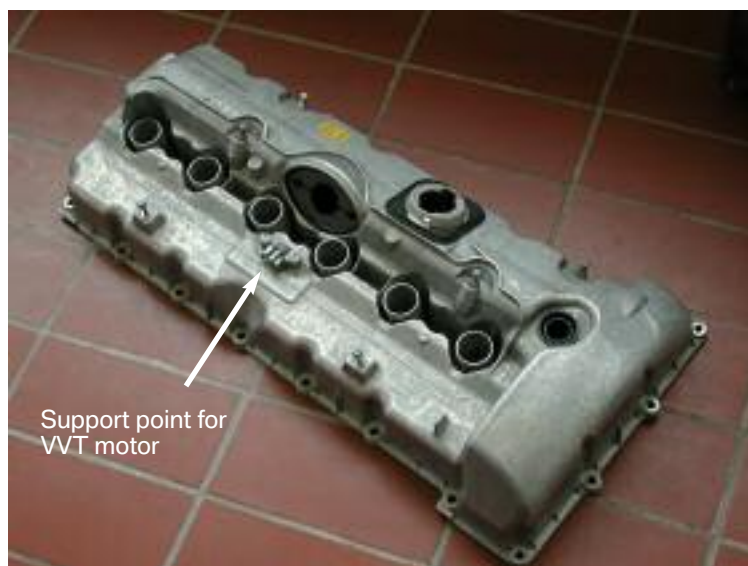

Valvetrain

The valvetrain on the N52 uses the familiar 4 valve per cylinder arrangement used on previous engines. The N52 valvetrain also uses the proven Valvetronic technology which was introduced on the N62.

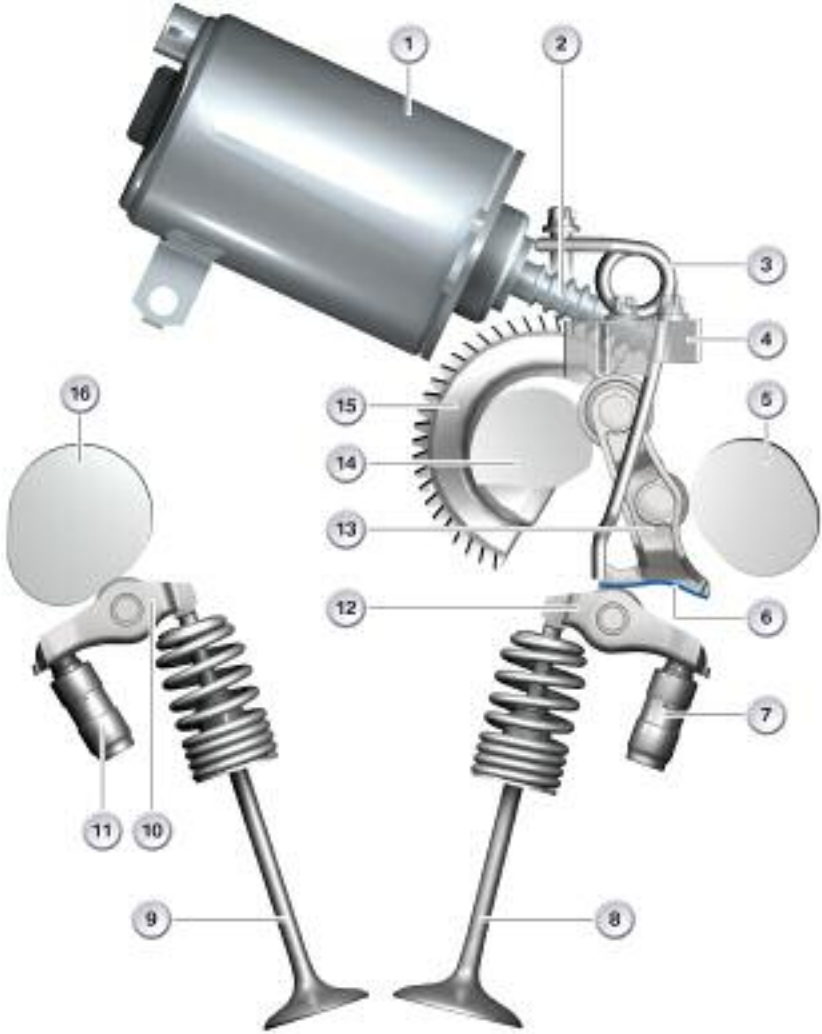

Index	Explanation	Index	Explanation
1	Actuator	9	Exhaust Valve
2	Worm Shaft	10	Roller Cam Follower
3	Return Spring	11	HVA, exhaust
4	Gate Block	12	Roller Cam Follower, Intake
5	Intake Camshaft	13	Intermediate Lever
6	Ramp	14	Eccentric Shaft
7	HVA, Intake	15	Worm Gear
8	Intake Valve	16	Exhaust Camshaft

Camshaft

The total weight of the N52 is additionally reduced by the lighter camshafts. The total weight of the camshafts has been reduced by approximately 25% using “hydroforming” technology during the manufacturing process.

The hydroforming process starts with a steel tube on which hardened camshaft lobe “rings” are fitted. The camshaft assembly is then placed into a die. The steel tube is then subjected to an internal water pressure of up to 4000 bar. The tube then conforms to the inside of the die and achieves the desired shape. The camshaft lobes are then polished to the desired finish.

The weight savings is approximately 600 grams (21 oz) per camshaft.

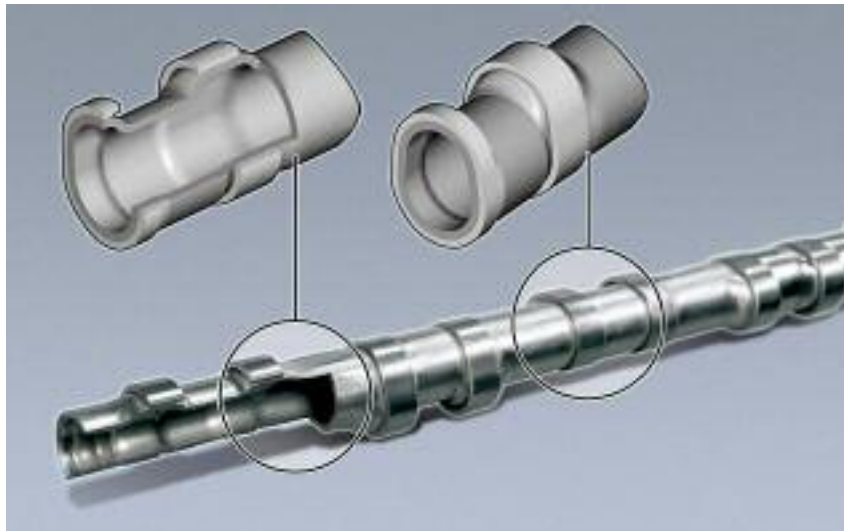

VANOS

Additional weight savings is also found on the VANOS system as well. The design of the VANOS is similar to that found on the N62.

The VANOS units are compact and use the “vane-type” construction which is less complex and easier to service than previous 6-cylinder VANOS designs. The VANOS units have integrated sprockets and are attached to the camshaft via a central bolt.

Due to the different spread ranges for the intake and exhaust camshaft, the VANOS units cannot be interchanged. Doing so would cause considerable engine damage.



Intake Manifold

The intake manifold is manufactured from lightweight thermo-plastic. The manifold provides the mounting for the 2 airflap actuators for the three-stage DISA system as well as the electronic throttle flap actuator.



Crankcase Ventilation

The crankcase ventilation system is attached to the rear of intake manifold. The system is now heated to prevent moisture from affecting system operation during low ambient temperatures. The heating system is controlled by the MSV70 engine management system via a relay.



Exhaust Manifold

The exhaust manifold has been modified to offer substantial weight savings over the previous design. The mounting flange has been lightened by using sheet steel with a new sealing design. The flange is approximately 2mm thick, as compared to the M54 design which is approximately 12mm thick.



The manifold uses a new circular seal which contains graphite. The new design features a thin-walled catalyst which reaches operating temperature faster. This eliminates the need for secondary air injection on some applications. The catalysts are also mounted near the engine as in the past. There are also provisions for the mounting of the pre and post catalyst oxygen sensors.



Gaskets/Seals

In order to prevent contact corrosion, a non-conductive gasket is placed between select engine components. This is the function of the oil pan and cylinder head gasket.

The oil pan separates the aluminum oil pan from the magnesium crankcase (bedplate).
The cylinder head gasket separates the aluminum cylinder head from the magnesium crankcase.

The cylinder head gasket features a sealing lip which protrudes from the block. This lip prevents dirt and splashing water from bridging the sealed joint, which prevents contact of these metals.



Particular care must be taken to ensure that the gaskets are not damaged during service. If gasket damage occurs, contact corrosion could form between the aluminum of the cylinder head and the magnesium of the crankcase within a relatively short period of time.

If the damage to the gasket were deep enough, the steel in the the core of the gasket could also have an effect on the corrosion process.

Bolts

Due to the magnesium construction, any ancillary components which are attached to the engine exterior are connected by aluminum bolts.

The aluminum bolts are needed to prevent contact corrosion. Conventional steel cannot be used in magnesium for any reason. The aluminum bolts can be identified by a blue colored bolt head and their light weight.

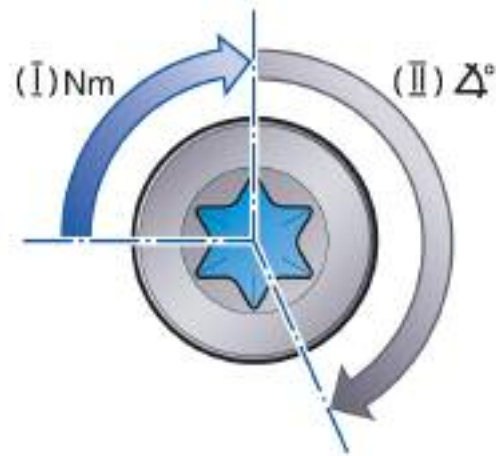

Also, the aluminum bolts can only be used once and must be replaced after each use.

When replacing components requiring aluminum bolts, torquing procedures must be strictly followed.

Torquing procedures include specific guidelines to prevent under or over torquing of the attachment bolts.

The procedures are outlined as follows:

- The bolt is tightened to a specific application torque to remove any slack between the components to be joined.
- The bolt is then tightened using the “angle torquing” method using a specific angle found in the tightening torques section of WebTIS.

Also, during any service procedures which involve coolant such as cylinder head replacement, the bolt holes must be blown dry immediately. Coolant must not be allowed to sit in any holes, this prevents any corrosion which could be caused by the coolant coming into contact with magnesium components.

Oil Pump

The high oil volume demands of the VANOS system on the N52 create a need for an oil pump that can deliver a high volume of oil when needed. Also, the pump needs to be able to cut back on the oil delivery volume when the requirements are not as great.

This occurs when the VANOS is not as active, for instance during cruise situations.

This new oil pump is a “volume controlled” design which not only meets the oiling requirements, but also contributes to improved fuel economy and emissions.

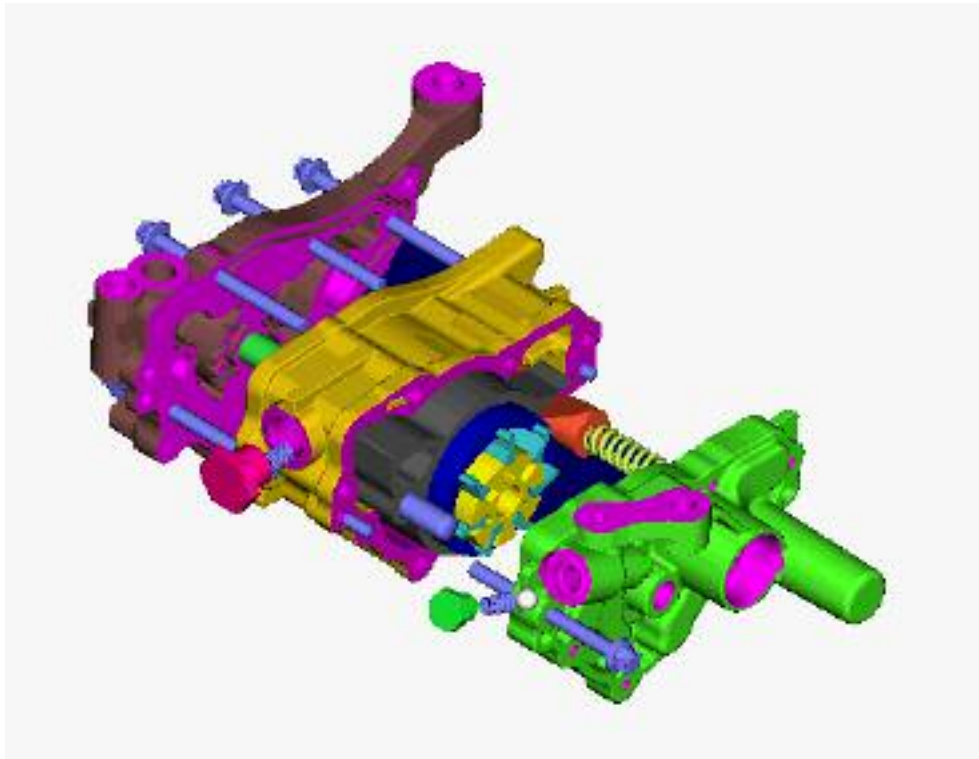

The advantages of a volumetric-flow controlled oil pump:

- Favorable space/efficiency ratio
- Provides sufficient hydraulic pressure and volume for valve control systems
- Reduced volumetric flow fluctuations
- Hydraulic energy not converted into thermal loss
- Reduction of premature oil ageing
- Reduced sound emissions

Electric Water Pump

The coolant pump on the N52 is designed as an electrically driven centrifugal pump. The output of the wet-rotor electric motor is controlled electronically by the electronic module (EWPU) located under the connection cover of the motor.



The EWPU is connected via the bit-serial data interface to the DME engine control unit. The engine control unit determines the necessary cooling capacity from the engine load, operating mode and the data from the temperature sensor and sends the corresponding instruction to the EWPU control unit.

The coolant in the system flows through the motor of the coolant pump, thus cooling both the motor as well as the electronic module.

The coolant also lubricates the bearings of the electric coolant pump.

Note: Particular care must be taken when performing servicing work to ensure that the pump does not run dry. When the pump is removed, it should be stored filled with coolant. The bearing points of the pump could seize if the pump were not filled with coolant. This could jeopardize subsequent start-up of the pump thus rendering the entire heat management system inoperative (the pump not starting up could cause serious engine damage). If the pump should ever run dry, the pump wheel should be turned by hand before finally connecting the coolant hoses. The system should then be immediately filled with coolant.

Particular care must be taken during assembly to ensure that the connector is clean and dry and the connections are undamaged. Diagnosis should be performed only with the approved adapter cables. The information provided in the repair instructions must be observed.

Map Controlled Thermostat

The map controlled thermostat is located externally near the electric water pump. The thermostat is controlled by the ECM and operates in conjunction with the N52 Heat Management System.



Oil-to Water Heat Exchanger (5 Series)

The oil-to-water heat exchanger is connected both to the oil circuit as well as to the water circuit of the engine. This arrangement ensures that the coolant quickly heats up the engine oil when the engine is cold and the coolant cools the engine oil when the engine is hot. Shortening the warm-up phase contributes to reducing the overall fuel consumption. The engine oil is cooled in order to extend its service life.



Vacuum Pump

Just as with the N62 engine, the N52 has little vacuum available in the intake manifold to operate certain components.

The N52 engine uses a vacuum pump driven by the camshaft chain drive.

The vacuum pump supplies vacuum to the brake booster and the exhaust flap damper. The exhaust flap damper system no longer requires the vacuum storage reservoir used on past models. This is due to the use of the vacuum pump. The flap operation is no longer affected by variations in intake manifold vacuum.



Alternator

The alternator is a 180 amp unit manufactured by Valeo. The alternator uses a one way clutch on the pulley. The alternator is capable of over-running when the battery is in a full state of charge. This prevents the inertia created by the rotating alternator from causing belt slippage on deceleration. Also, the service life of the belt tensioner is increased.

The alternator communicates with the ECM via the BSD line.

Note: the one way clutch is also used on Bosch alternators as well (N52).





Workshop Exercise - N52 Engine

Using an instructor designated engine trainer, remove the VVT motor, cylinder head(valve) cover and eccentric shaft sensor using proper repair procedures.

What special precautions must be observed when removing VVT motor?

Continue to remove valve cover and eccentric shaft sensor.

Complete the table below and check off which bolts are steel or aluminum:

Bolt Description	Aluminum Bolt	Steel Bolt
Example >	X	
Valve Cover Bolts		
VVT Motor Flange (to cylinder head)		
VVT rear support (to valve cover)		
Engine Acoustic Cover (on vehicle)		

What are the special concerns regarding the cleaning of the cylinder head or valve cover sealing surfaces?

What is important regarding the eccentric shaft sensor wheel mounting bolt?

Once the VVT motor, cylinder head cover and eccentric shaft sensor are removed, rotate the engine so the #1 cylinder is at TDC (compression stroke). Install flywheel locking tool and camshaft locking tool.

Before continuing, invert engine on stand and remove oil pan.



Workshop Exercise - N52 Engine

Once oil pan is removed, continue with removal of oil pump pickup tube and oil deflector.

Complete the table below and check off which bolts are steel or aluminum:

Bolt Description	Aluminum Bolt	Steel Bolt
Example >	X	
Oil pan bolts		
Oil deflector bolts		

Invert engine back to upright position and continue with removal of VANOS and timing chain assembly.

Remove VANOS solenoids and camshaft sensors.

Complete the table below and check off which bolts are steel or aluminum:

Bolt Description	Aluminum Bolt	Steel Bolt
Example >	X	
VANOS solenoid retaining bolts		
Camshaft sensor retaining bolts		

Remove timing chain tensioner. Remove intake and exhaust VANOS units.

Are the exhaust and intake VANOS adjustment units interchangeable? Why or Why not?

Are the camshaft sensor gears interchangeable?

Does the timing chain tensioner have a seal/gasket. Why or why not?



Workshop Exercise - N52 Engine

Once the VANOS adjustment units are removed, continue with removal of the timing chain assembly.

Remove upper timing chain guide by unclipping from lower chain guide. Suspend timing chain using upper guide bolts.

Remove screw plugs from timing case to access timing chain guide retaining bolts. Remove timing chain guide bolts.

Remove crankshaft central bolt and remove from crankshaft hub. Remove timing chain, chain guides and crankshaft sprocket as an assembly.

Describe the installation position of the crankshaft sprocket:

What is unique about the front crankshaft hub assembly?

Once the timing chain has been removed, invert engine (crank side up) and remove oil pump chain module and oil pump.

Complete the table below and check off which bolts are steel or aluminum:

Bolt Description	Aluminum Bolt	Steel Bolt
Example >	X	
Oil pump chain module bolts		
Oil pump mounting bolts.		

Proceed with removal of the bedplate assembly. Remove flywheel temporarily to facilitate bedplate removal. (Do not rotate engine due to possible piston to valve contact).

Lift out bedplate assembly and note sealant passages in crankcase and bedplate.

Complete the table below and check off which bolts are steel or aluminum:

Bolt Description	Aluminum Bolt	Steel Bolt
Example >	X	
Outer bedplate bolts		
Main bearing bolts		



Workshop Exercise - N52 Engine

Re-install bedplate following proper procedures and sequences. (Do not tighten bolts to specification. For training purposes, tighten bolts only “hand tight”).

Bolt Description	Joining Torque	Torque Angle
Outer bedplate bolts (M10X27)		
Outer bedplate bolts (M8 X37)		
Outer bedplate bolts (M10 X 41)		
Main bearing bolts		

Complete the chart below using the proper torque specifications:

Re-install flywheel and crankshaft locking pin. Note correct position of locking pin.

Re-install oil pump noting correct position of bolts.

Complete the chart below using the proper torque specifications:

Bolt Description	Joining Torque	Torque Angle
Oil pump to bedplate (M8 X 123)		
Oil pump to bedplate (M8 X 31)		

Re-install oil pump drive using proper procedures.

What special tool is used to retain oil pump chain tensioner?

Install bolts on oil pump and vacuum pump sprockets. Re-install oil pump pickup and deflector plate.

Complete the chart below using the proper torque specifications:

Bolt Description	Joining Torque	Torque Angle
Oil pump chain module to crankcase and oil pump (M6 X16)		
Oil Pump Sprocket		
Vacuum Pump Sprocket		
Oil deflector bolts		



Workshop Exercise - N52 Engine

Invert engine to upright position and reinstall timing chain guides and crankshaft hub. Be sure to install crankshaft sprocket correctly.

Temporarily install VANOS actuators and upper timing chain guide. Proceed with removal of the exhaust camshaft.

Temporarily remove camshaft locking tool.

What special procedures should be observed when removing exhaust camshaft bolts?

Remove exhaust camshaft and note position of camshaft followers. Re-install exhaust camshaft using proper procedures.

What special tool(s) should be installed before the exhaust camshaft and Why?

What other precautions should be taken when installing the exhaust camshaft?

What are the special torquing instructions when installing the exhaust camshaft?

What special tools are used when performing final torque on the exhaust camshaft mounting bolts?

Note: Ask instructor to explain access to head bolts and special tools.



Workshop Exercise - N52 Engine

When the exhaust camshaft installation is complete, continue setting the camshaft timing.

What special tool is used to align the camshaft sensor trigger wheels?

Do the retaining bolts for the VANOS actuators need to be replaced?

What special tools are needed to pre-tension the timing chain?

Complete the chart below using the proper torque specifications:

Bolt Description	Joining Torque	Torque Angle
VANOS actuator retaining bolts		
Pre-tension of timing chain using 00 9 250		
Crankshaft center bolt		
Timing case plug (M18 x1.5)		
Chain guide rail (cylinder head M8)		
Chain guide rail (crankcase M7)		

Once the camshaft (valve) timing is set, proceed with Valvetronic disassembly.

Remove and install intermediate levers on one cylinder using proper procedures.

What special tool is needed to relieve tension on the retaining spring?

Why is it important to NOT mix up Valvetronic components between cylinders?



Workshop Exercise - N52 Engine

Why is it important to remove oil from the mounting surfaces of the guide blocks before re-assembly?

What special tool is used to pre-tension the guide blocks during re-assembly?

Complete the chart below using the proper torque specifications and bolt materials:

Bolt Description	Bolt Material	Joining Torque	Torque Angle
Example	Steel	10 nM	90 Degrees
Guide block bolts			
Retaining spring bolts			

Upon completion of the intermediate shaft R&R, proceed with engine assembly.

Invert engine and install oil pan (sump).

Complete the chart below using the proper torque specifications and bolt materials:

Bolt Description	Bolt Material	Joining Torque	Torque Angle
Example	Steel	10 nM	90 Degrees
Oil sump (M8 x 26)			
Oil sump (M8 x 92)			
Oil sump (M8 x 112)			
Oil sump (M8 x 24) All Wheel drive only			

Invert engine to the upright position and continue with re-assembly. Install eccentric shaft sensor (if not already done), cylinder head cover and VVT motor.



Workshop Exercise - N52 Engine

Re-Install cylinder head cover using proper procedures.

What is important regarding the VVT mounting bolts?

Complete the chart below using the proper torque specifications and bolt materials:

Bolt Description	Bolt Material	Joining Torque	Torque Angle
Example	Steel	10 nM	90 Degrees
Cylinder head cover			
VVT motor flange to head			
VVT motor rear support			

Check over the engine and ensure that all components have been re-installed.

What special procedures should be observed when cleaning gasket surfaces on a magnesium engine?

What special procedures should be followed to allow access to the cylinder head bolts?



Workshop Exercise - N52 Engine

Fill in the chart below regarding engine materials

Component	Material
Crankcase	
Bedplate	
Cylinder Bore	
Cylinder Head	
Cylinder Head Cover	
Oil Sump (pan)	
Head Bolts	
Crankshaft	
Camshafts	

Principle of Operation

Magnesium - new material in engine construction

Until now, magnesium has not been explored as an option for a material for engine construction. Recently, the realization is that the weight savings potential of aluminum has been exploited to its fullest. **This is one of the primary factors in the decision to use magnesium as engine building material. The light weight and low density of magnesium make it an outstanding option to aluminum.**

Magnesium, which has very good casting properties, makes it possible to manufacture large components with high surface quality. Despite the high accuracy of the cast parts, subsequent machining of function areas is, however, in the majority of cases unavoidable.

These excellent properties are, however, offset by several problematic aspects in the use of magnesium and its alloys. **The former serious problem of corrosion has in the meantime been substantially alleviated by the development of distinctly more corrosion resistant alloys.** The alloy used for the N52 is designated AJ62.

Nevertheless, a distinct corrosion risk still exists if the material-specific fundamentals described in the following are disregarded. Non-approved materials that come in contact with magnesium must not be installed.

This means only genuine BMW spare parts must be installed. The materials of the add-on parts must either be compatible with AJ62 or shielded by a seal/gasket from the magnesium casing. For these reasons, it is important to strictly adhere to the corresponding information provided in the repair instructions.

Electrochemical Properties of Magnesium

Metals are divided into noble (precious) and base metals. Gold, for example, is a noble metal and sodium a very base metal. The other metals are distributed over this division. When two metals such as iron and magnesium in contact with each other are placed in an electrically conductive liquid, e.g. a salt solution, the base metal will break down or dissolve and go into solution.

At the same time, electric current flows from the noble metal to the base metal. Under certain conditions, the base metal will deposit itself on the noble metal.

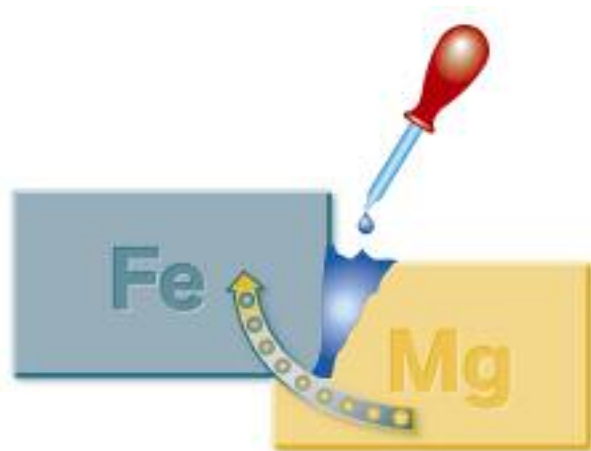

Magnesium is a base metal. Its surface is therefore very susceptible to other materials. The magnesium alloy used in the N52, however, is completely different: By mixing other metals the negative properties of the pure metal are essentially cancelled out so that it is capable of satisfying the demands made of it.

An electrical voltage occurs between the two metals in the electrolyte. All metals can be classified based on this voltage. Iron assumes a mid-position in the voltage range while, on the other hand, aluminum and particularly magnesium are base. The greater the voltage difference between the metals, the faster electrochemical corrosion takes place.

The described laboratory situation can also easily occur on the engine when two metals make direct contact and the contact surface is moistened by splash water for instance. So-called contact corrosion takes place. A gap between the contact surfaces in which moisture can collect further promotes the occurrence of contact corrosion.

Contact corrosion can be avoided by keeping the contact surfaces dry or wetting them with electrically non-conductive engine oil. For this reason, all contact surfaces in the engine involving magnesium, aluminum and steel pose no problems.

Physical Properties of the Materials

Magnesium and aluminum have a virtually identical coefficient of expansion which, however, is almost double that of steel:

- Magnesium: 0.0026% per °C
- Aluminum: 0.0023% per °C
- Steel: 0.0011% per °C

The melting temperature of magnesium also barely differs from that of aluminum. On the other hand, the melting point of steel is considerably higher:

- Magnesium: 650 °C
- Aluminum: 660 °C
- Steel: 1,750 °C

The electrical conductivity of aluminum and magnesium is considerably better than that of steel. These materials are therefore particularly suitable for shielding electromagnetic interference (e.g. from the ignition spark).

No problems are encountered when connecting aluminum and magnesium as both materials have the same coefficient of expansion. However, no steel screw/bolts can be used on the N52 engine due to the fact that the coefficient of expansion of steel is only half as much. When the engine heats up, a steel bolt expands at only approximately half the rate of the crankcase. Conversely, there is the risk that a screw connection could become loose as the engine cools down. For this reason, aluminum bolts/screws are used at the decisive points.

VALVETRONIC II

With the introduction of the N52, the 6-cylinder, engine is now also equipped with the load control system based on the valve timing gear. The VALVETRONIC I system that was used on the 8-cylinder and 12-cylinder engines already achieved a substantial increase in efficiency.



BMW has further developed this concept with the VALVETRONIC II.

The results of this further development are:

- Increased engine dynamics
- Increased efficiency
- Improved emission values

These results underscore BMW-specific standards. This engine that features the following optimizations further enhances the Ultimate Driving Machine.

- The top engine speed has been increased to 7,000 rpm
- The specific power output has been increased to 63.4 kW/l (85 hp/liter).
- The specific engine torque is 100 Nm/l over a broad engine speed range
- Distinctly increased valve acceleration values and friction-optimized transmission elements result in an even more responsive engine
- CO2 emissions reduced
- The world's most stringent exhaust emission regulations are complied with

Load Control

The illustration on the left below shows the conventional method with the slightly higher loss. The reduced loss can be clearly seen in the illustration on the right. The upper area represents the power gained from the combustion process in the petrol engine. The lower area illustrates the loss in this process.

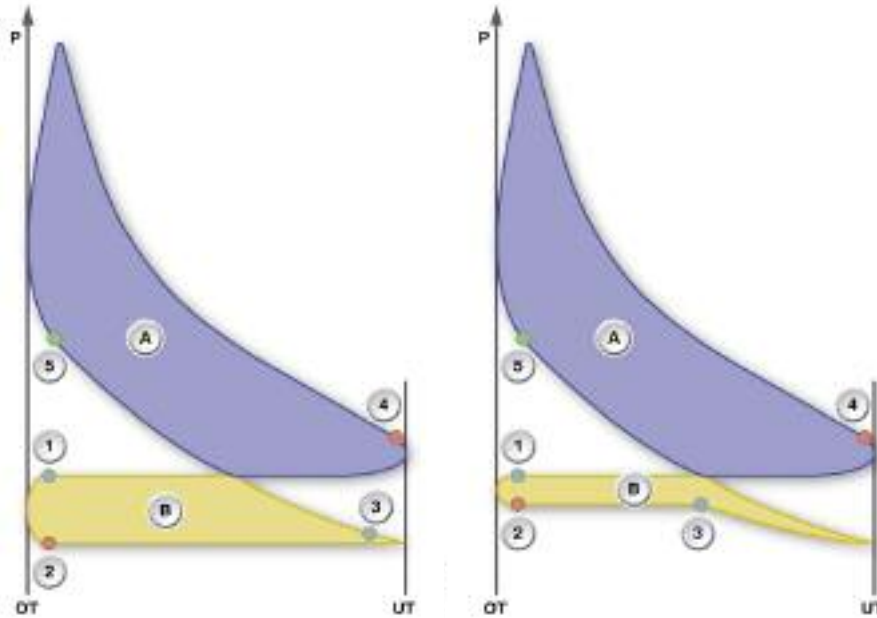

Index	Explanation	Index	Explanation
OT	Top dead center	4	Exhaust valve opens
UT	Bottom dead center	5	Firing point
1	Intake valve opens	A	Gain
2	Exhaust valve closes	B	Loss
3	Intake valve closes	P	Pressure

The loss area can be equated to the charge cycle, relating to the amount of energy that must be applied in order to expel the combusted exhaust gasses from the cylinder and then to draw the fresh gasses again into the cylinder. Apart from the full load setting, the intake of fresh gasses in a throttle valve controlled engine always takes place against the resistance offered by the throttle valve to the inflowing gasses. The throttle valve is virtually always fully opened during intake on the VALVETRONIC-controlled engine. The load is controlled by the closing timing of the valve.

Compared to the conventional engine where the load is controlled by the throttle valve, no vacuum occurs in the intake manifold. This means no energy is expended for the purpose of producing the vacuum. The improved efficiency is achieved by the lower power loss during the intake process.

A minimum vacuum in the intake system is required for the crankcase ventilation and evaporative (purge) systems. The throttle valve is slightly adjusted for this purpose.

Design/Function

The VALVETRONIC II consists of the fully variable valve lift control combined with the variable camshaft control (double VANOS). The valve lift is controlled only on the intake side while the camshaft is adjusted also on the exhaust side.

The throttle-free load control is implemented by variable valve lift of the intake valve, variable valve opening timing of the intake valve and variable camshaft spread of the intake and exhaust camshaft.

In terms of this load control principle, the VALVETRONIC II corresponds to the VALVETRONIC I introduced on the N62 engine.

System optimization includes modification of the valve gear kinematics, a modified actuator motor and the adapted spread range of the VANOS units.

The main differences are:

- The plain bearing on the intermediate lever to the eccentric shaft has been replaced by a roller bearing, thus reducing the friction in the valve timing gear.
- Guidance of the intermediate lever is more precise. Only one spring is now required to guide and hold the intermediate lever.
- The moved mass of the valve timing gear has been reduced by 13%.
- The lift range of the intake valves has been improved. The maximum lift has been increased to 9.9 mm but more importantly the minimum lift has been further reduced to 0.18 mm.

The overall result is supported by further improvements in the intake manifold and exhaust dynamics.

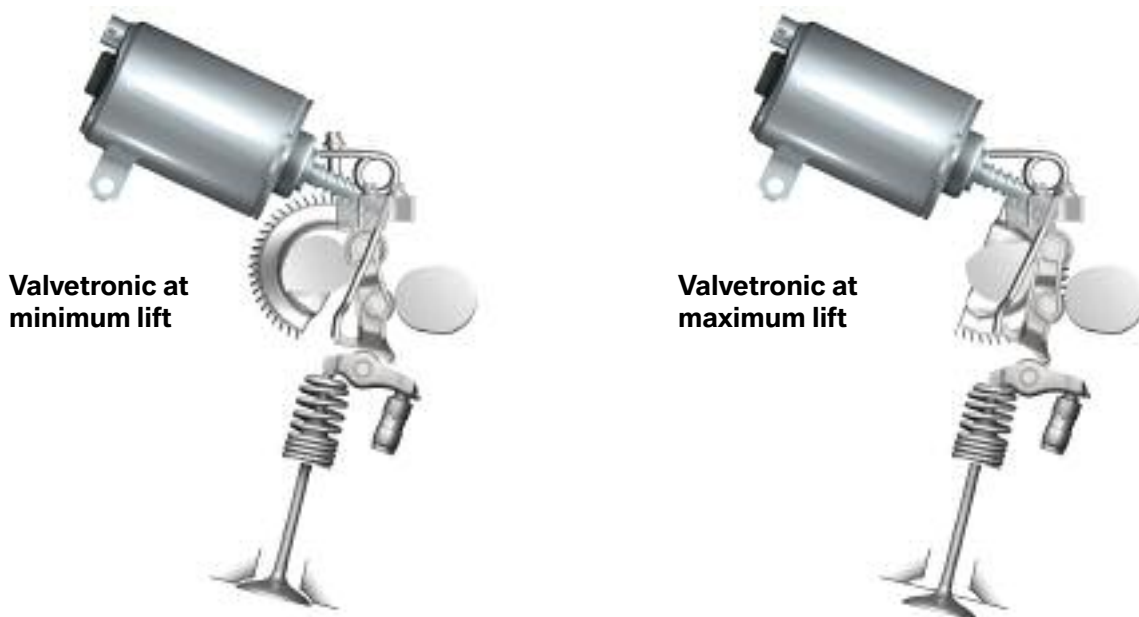

VANOS

The N52 is equipped with a compact, infinitely variable vane-type VANOS unit for the intake and the exhaust side. The VANOS units can be easily disassembled and assembled. They are designed as an integrated component in the chain drive and are mounted with a central bolt on the respective camshaft. When de-pressurized, a coil spring holds the VANOS unit in the base position.

The VANOS units are controlled by oil pressure from the 4/3 proportional solenoid valves. The valves are located in the front of the cylinder head and are controlled by the ECM. The ECM regulates the VANOS based on factors such as engine RPM, load and coolant temperature.

The operation of the VANOS units is similar to the N62 engine.



VANOS unit (front view)



VANOS unit (rear view)

When servicing the VANOS units, the repair instructions must be followed precisely. The VANOS unit can no longer be dismantled and they must not be interchanged as they have different spread ranges for the intake camshaft and exhaust camshaft. Installing the wrong VANOS unit can cause considerable engine damage.

Differential Intake Air Control (DISA)

The torque developed in an engine greatly depends on the quality of the fresh gas charge during the induction stroke.

Oscillations are induced in the intake air mass during the induction strokes of the individual cylinders, i.e. by the downward movement of the pistons. These oscillations are in turn superimposed by oscillations that arise from pressure peaks as soon as the moved air mass of an intake cylinder comes up against the closing intake valves.

When two oscillations are superimposed, the resulting oscillation is known as the resonance oscillation or sympathetic vibration. The resonance can be an amplification or an attenuation of the initial oscillation or vibration.

Whether a pressure peak or a pressure hole is applied before the intake valves at the cylinder at the start of the induction stroke depends on the path the superimposed oscillations have covered in the intake area and on the engine speed, i.e. the gas speed.

The desire for high torque over a broad engine speed range necessitates an increasingly diverse range of air intake systems for internal combustion engines. The geometry and control of the intake manifold therefore have a considerable influence on the quality of the charge cycle. An intake manifold with a fixed length would provide an optimum cylinder charge only at a certain engine speed.

For this purpose, the M54 is equipped with a two-stage differentiated intake manifold (DISA) with a DISA valve (flap). The DISA valve is activated by means of a solenoid and an upstream vacuum accumulator.

The options of boosting torque over a defined engine speed window are limited. Since the N52 reaches a maximum engine speed of 7,000 rpm, the previous 2-stage DISA would produce a torque lag in the mid engine speed range. The N52 is equipped with a 3-stage DISA in order to provide high torque also in the medium engine speed range.

The result of these three stages is illustrated in the diagram below. The switched stages of the DISA achieve a high torque over the entire engine speed range. This principle is realized by means of an intake manifold changeover facility with two DISA actuators and an overflow pipe in the intake area.

In contrast to the previous system that was controlled with vacuum, the two DISA actuators are now operated by electric motors.

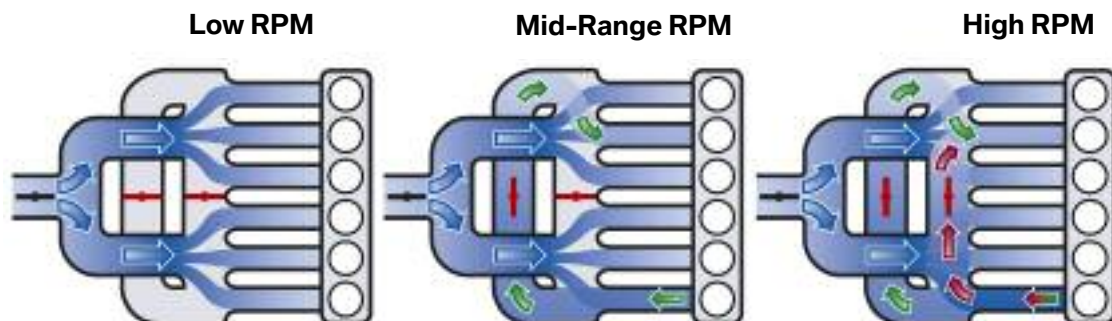

The electric motors and DISA actuators form one unit. The two DISA actuators differ in size. The DISA actuator 2 is installed in the overflow pipe and the DISA actuator 1 is installed in the intake air manifold ahead of the resonating intake runner.



DISA Actuator



DISA Actuator

Stage 1 - Idle/lower engine speed range

The DISA actuators 1 and 2 are closed in the idle speed and lower engine speed range. The air drawn in flows past the throttle valve into the resonance pipe. The air mass is split in the resonance pipe and is routed further via the collector runner and the intake resonating runners into the individual cylinders. In this way, a comparably large air mass is made available to three cylinders.

Stage 2 - Medium engine speed range

DISA actuator 2 is open in the medium engine speed range. In this example it is assumed that the intake valves of the first cylinder are just closing. The gas movement produces pressure peaks at the closing intake valves.

This is continued via the resonating and manifold runners at the next cylinder in the firing order thus improving fresh gas charge of the next cylinder to be charged.

Stage 3 - Upper engine speed range

Both DISA actuators are opened in the upper engine speed range. Also in this case it is assumed that the intake valves of the first cylinder are just closing. The pressure peaks ahead of the closing intake valves are also utilized in this case. The intake air mass is now routed via the resonance, overflow and manifold runners.

DISA Actuators

Together with the drive, the DISA valve (flap) forms one unit. The DISA valve is driven by an electric motor and a gear mechanism.

The electronic control is integrated in the DISA actuator. The DISA actuator is driven by a pulse width-modulated signal from the DME MSV70.

There are only two possible positions: The valves (flaps) can either be closed or opened, i.e. when activated, the motor moves the valve to the respective end position.

Lubrication System

To meet the oiling requirements of the N52, a new “volumetric-flow controlled” oil pump is utilized. Systems such as VANOS require a large volume of oil, particularly at low engine speeds.

To keep up with the volume requirements, a conventional oil pump would need to be 3 times as large as the new oil pump design. A larger oil pump would also consume excess energy and therefore the new pump design allows:

- Increased power output
- Reduced weight
- Optimized fuel consumption
- Reduced exhaust emissions

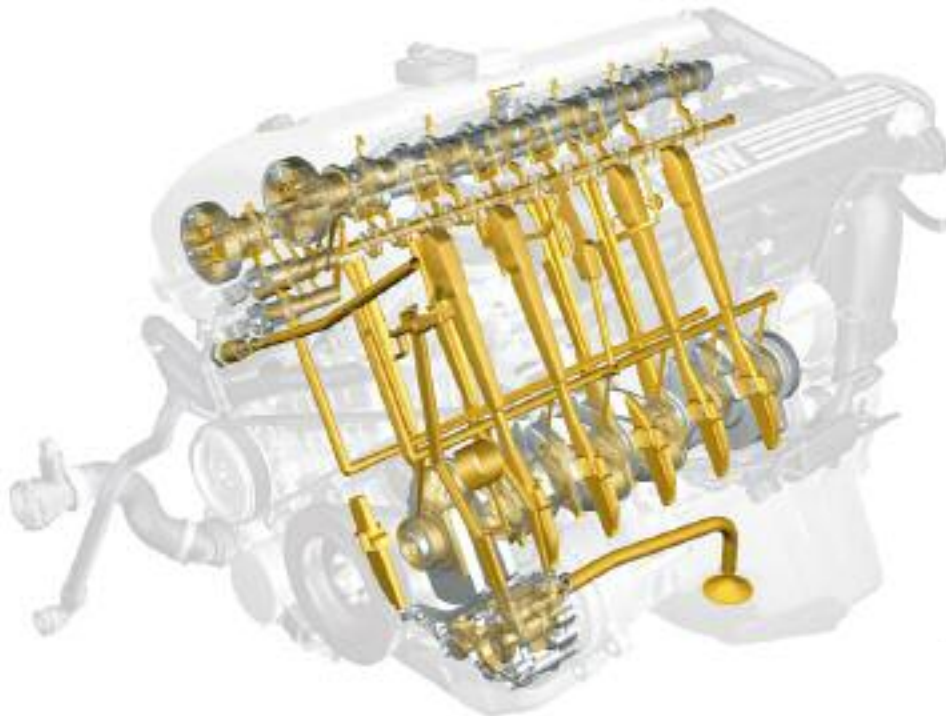

The savings potential of the new optimized pump system is a good reason to employ this new design.

The tasks of the engine oiling system includes:

- The lubrication of friction surfaces in the engine
- The cooling of part subject to high load
- Carrying away abrasive particles
- Provides a hydraulic control medium (for VANOS etc)
- Protection against corrosion

The VANOS requires a large volume of oil particularly for the purpose of adjusting the camshaft angle. However, it requires no oil flow when the VANOS retains the set camshaft angle.

The oil requirement therefore depends on the extent of the required adjustment.

Conventional oil pumps produce the oil pressure necessary for the greatest possible oil flow that can occur in the engine. In many operating situations this situation represents unnecessary energy consumption through the oil pump and excessive wear of the oil.

The Valvetronic II and hot idle operation, therefore necessitate a new optimized pump system.

The highest control demands are placed on the double VANOS at idle speed and small valve lift rates. The adaptation requirement for the start of opening of the valves is proportionally the greatest under these operating conditions.

For the oil pump this means that it must deliver a large volume of oil to the VANOS units at relatively low engine speeds.

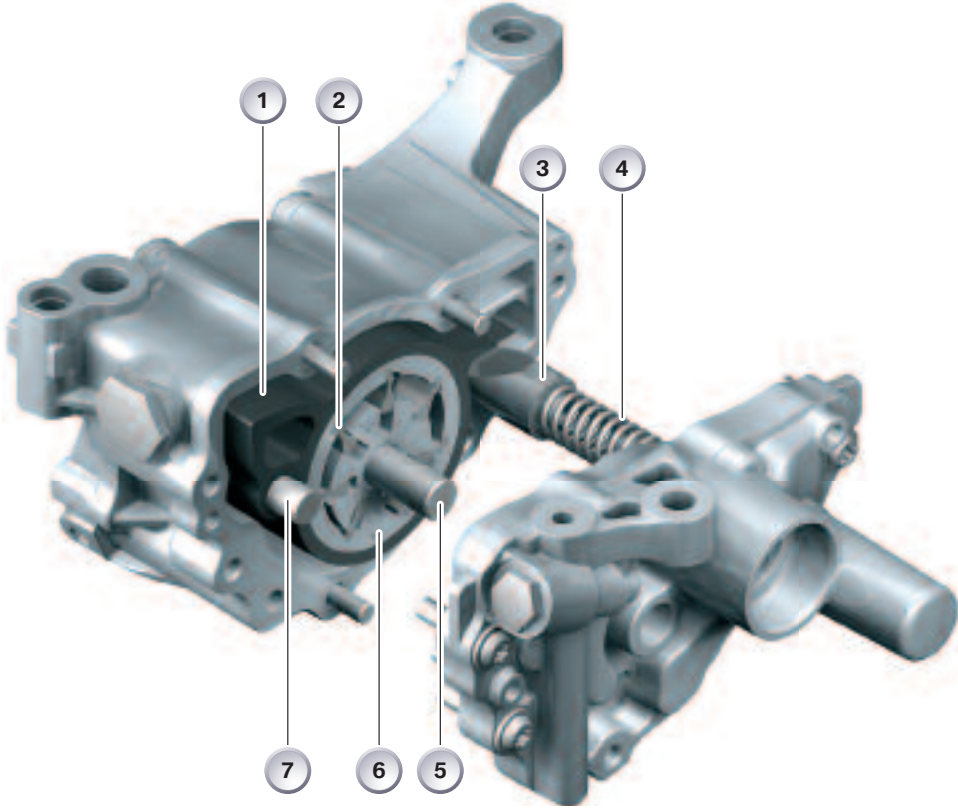

Index	Explanation	Index	Explanation
1	Vane	5	Pump Shaft
2	Slide Valve	6	Rotor
3	Control Piston with Pendulum Support	7	Pivot
4	Compression Spring		

To meet these demands, a conventional oil pump would have to be dimensioned 3 times as large as the oil pump used on the N52. It would also take up correspondingly more drive energy.

The N52 is equipped with a volumetric-flow controlled oil pump. This type of pump deliver only as much oil as is necessary under the respective engine operating conditions. No surplus quantities of oil are delivered in low load operating ranges. This reduces the fuel consumption of the engine and slows down the oil wear rate.

The pump is designed as a slide valve-type vane pump. In delivery mode, the pump shaft is positioned off-center in the housing and the vanes are displaced radially during rotation. As a result, the vanes form chambers of differing volume. The oil is drawn in as the volume increases and, conversely, expelled into the oil channels as the volume decreases.

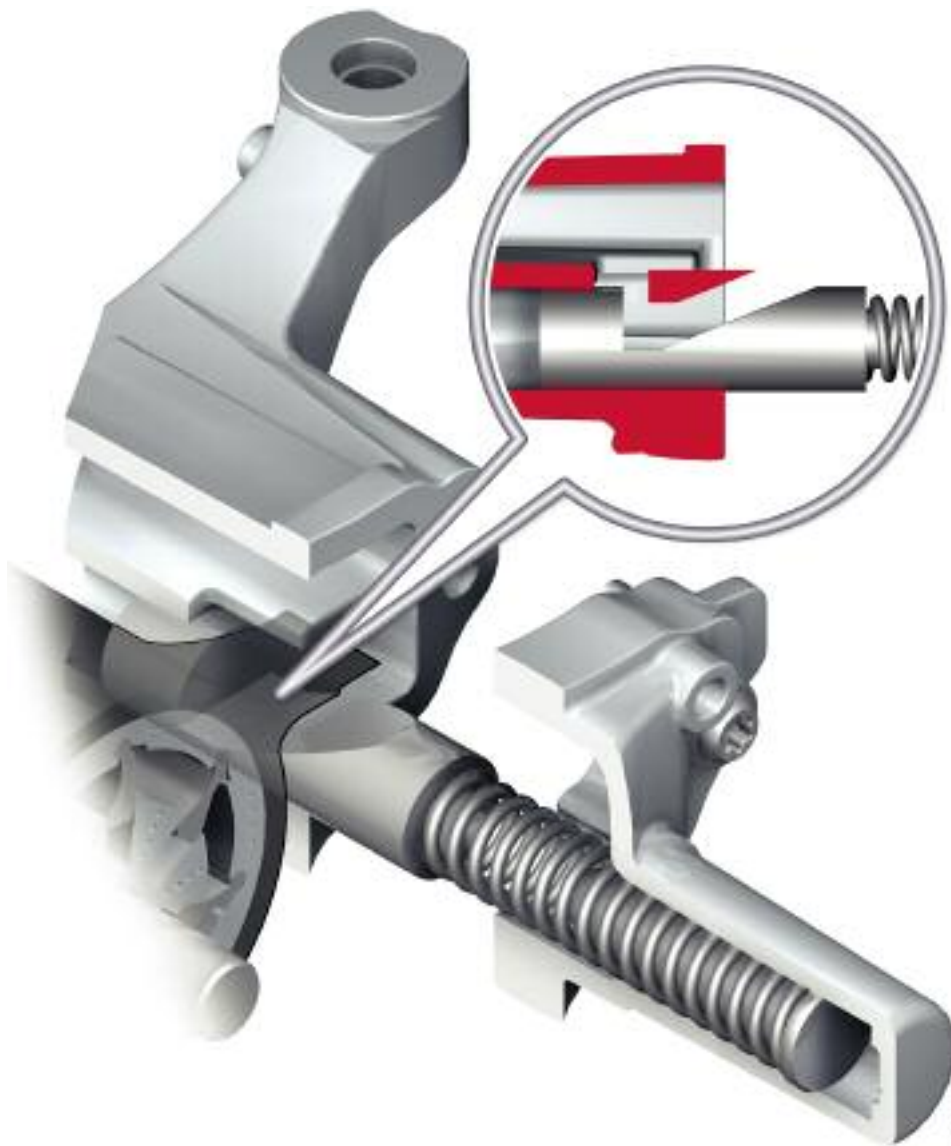

Oil Pump Operation

The crankshaft drives the pump with a chain. The applied oil pressure acts on the control spool with oblique stop face (pendulum support) against the force of a compression spring. The pendulum support varies the position of the slide valve. The changes in volume are small and the delivered volume is low when the pump shaft is positioned towards the center of the slide valve. The changes in volume and the delivered quantity are greater than the pump shaft is located off center. If the oil required by the engine increases, for example, VANOS control intervention, the pressure in the lubricating system drops and is therefore also reduced at the control spool. In response, the pump increases the delivery volume and re-establishes the pressure conditions. When the oil required by the engine decreases, the pump correspondingly reduces the delivery quantity towards the zero-delivery direction.

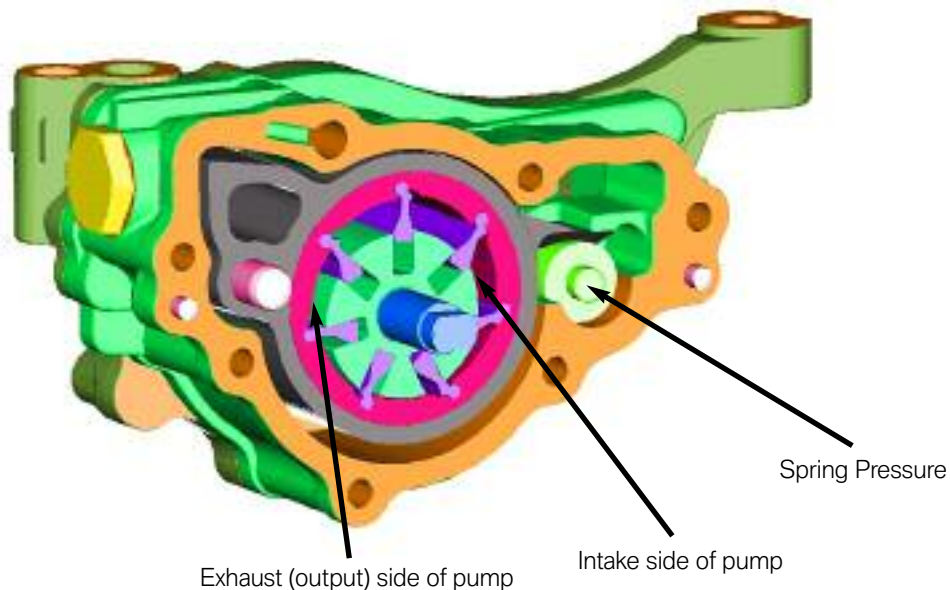

Electronic Oil Condition Monitoring

There is no dipstick including the guide tube on the N52 engine. This represents a convenience function for the customer while enabling more accurate recording of the engine oil level.

The engine oil level is measured by an oil condition sensor (OZS) and indicated in the central information display (CID). The engine oil temperature and the oil condition are also registered or calculated by the oil condition sensor. The signal from the oil condition sensor is evaluated in the ECM. The evaluated signal is then routed via the PT-CAN, SGM and the K-CAN to the instrument cluster and to the CID.

Registering the engine oil level in this way ensures the engine oil level in the engine does not reach critically low levels thus protecting the engine from the associated damage. By registering the oil condition, it is also possible to determine when the next engine oil change is due. Over filling the engine with oil can cause leaks - a corresponding warning is therefore given.

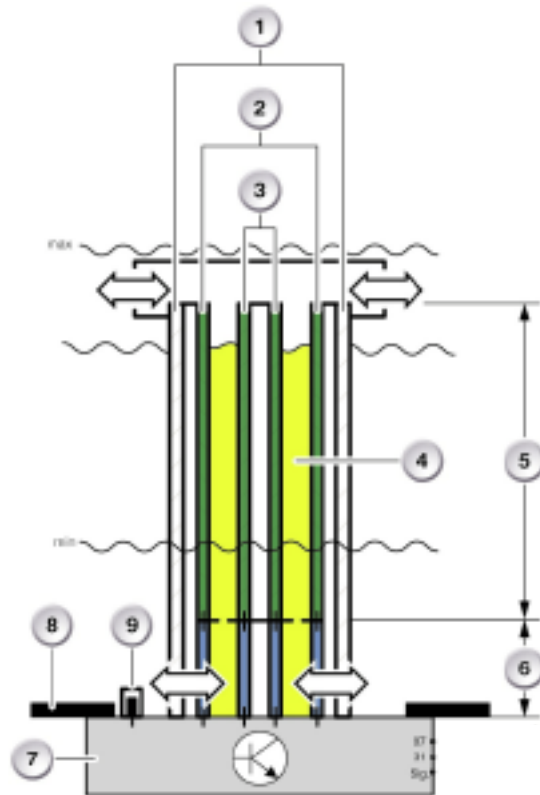

Index	Explanation	Index	Explanation
1	Housing	6	Oil Condition Sensor
2	Outer Metal Tube	7	Sensor Electronics
3	Inner Metal Tube	8	Oil Pan
4	Engine Oil	9	Temperature Sensor
5	Oil Level Sensor		

Function of the Oil Condition Sensor

The sensor consists of two cylindrical capacitors arranged one above the other. The oil condition is determined by the lower, smaller capacitor (6). Two metal tubes (2 + 3), arranged one in the other, serve as the capacitor electrodes. The dielectric is the engine oil (4) between the electrodes. The electrical property of the engine oil changes as the wear or ageing increases and the fuel additives break down.

The capacitance of the capacitor (oil condition sensor) changes in line with the change in the electrical material properties of the engine oil (dielectric). This means that this capacitance value is processed in the evaluation electronics (7) integrated in the sensor to form a digital signal.

The digital sensor signal is transferred to the DME as an indication of the status of the engine oil. This actual value is used in the DME to calculate the next oil change service due.

The engine oil level is determined in the upper part of the sensor (5). This part of the sensor is located at the same level as the oil in the oil pan. As the oil level drops (dielectric), the capacitance of the capacitor changes accordingly. The electronic circuitry in the sensor processes this capacitance value to form a digital signal and transfers the signal to the DME.

A platinum temperature sensor (9) is installed at the base of the oil condition sensor for the purpose of measuring the engine oil temperature.

The engine oil level, engine oil temperature and engine oil condition are registered continuously as long as voltage is applied at terminal 15. The oil condition sensor is powered via terminal 87.



Faults/Evaluation

The electronic circuitry in the oil condition sensor features a self-diagnosis function. A corresponding error message is sent to the DME in the event of a fault in the oil condition sensor.

Electronic Oil Level Indicator

The oil level is measured in two stages:

- Static oil level measurement while the vehicle is stationary
- Dynamic oil level measurement during vehicle operation

Static oil level measurement at engine OFF

This is only a reference measurement as the oil condition sensor (OZS) is flooded when the engine is turned off and can only detect the minimum oil level. The oil level is measured correctly only when the engine is running (see Dynamic oil level measurement).

After switching on the ignition, the static oil level measurement provides the driver with the opportunity of checking whether there is sufficient engine oil for safely and reliably starting the engine.

1. It is important that the vehicle is parked horizontally otherwise the oil level measurement may be incorrect.
2. Select on-board computer function "Service" -> "Oil level".

If there is sufficient engine oil for safe and reliable engine start, a graphic appears in the CID in the form of an engine with a green oil sump.



If the oil level is close to minimum, the graphic appears with a yellow oil sump and an oil dipstick that represents the low oil level in yellow.

A top-up request +1 liter additionally appears as a text message. The display will not change if less than 1 liter of oil is topped up. MAX is indicated only after topping up a quantity of 1 liter.

If the oil level drops below minimum, the graphic appears with a red oil sump and an oil dipstick that represents the low oil level in red.

A top-up request +1 liter will additionally appear as a text message.

The display will not change if less than 1 liter of oil is topped up. MAX is indicated only after topping up a quantity of 1 liter.

If the oil level is above maximum, the graphic appears with a yellow oil sump and an oil dipstick that represents the high oil level in yellow.

A text message is also displayed for the driver.

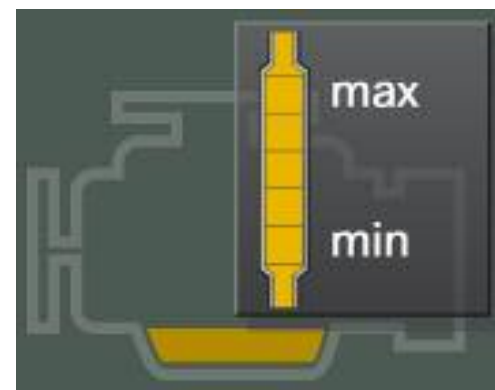
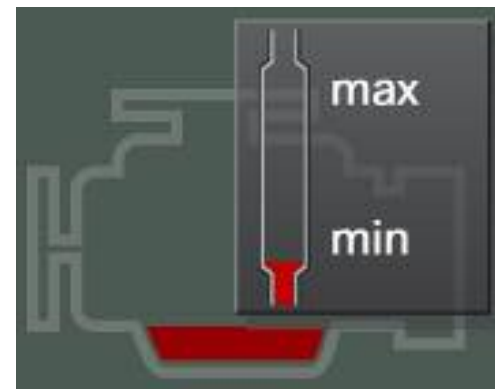
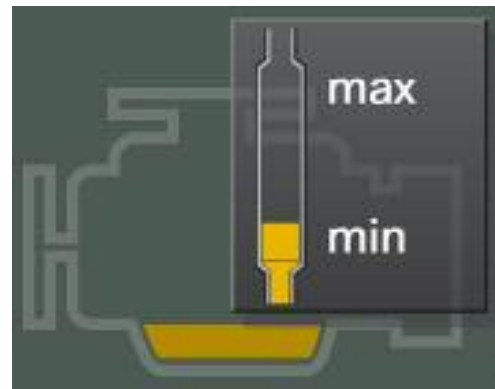

Dynamic oil level measurement during vehicle operation

Always perform the dynamic oil level measurement (app.. 5minutes driving time) after an oil change. The oil level could be misinterpreted as the oil level last stored is initially displayed after an oil change.

No oil level is initially stored after replacing or reprogramming the engine control unit. "Oil level below min" is therefore displayed. The correct oil level is indicated after running the engine for app.. 5 minutes.

1. Start engine.
2. Select on-board computer function - "Check oil level".
3. The oil level is measured. A clock symbol may appear while the level measurement is running. The clock symbol appears for up to 50 seconds after starting the engine when there is no measured value or the long-term value last stored is not within the tolerance range of the currently measured oil level.

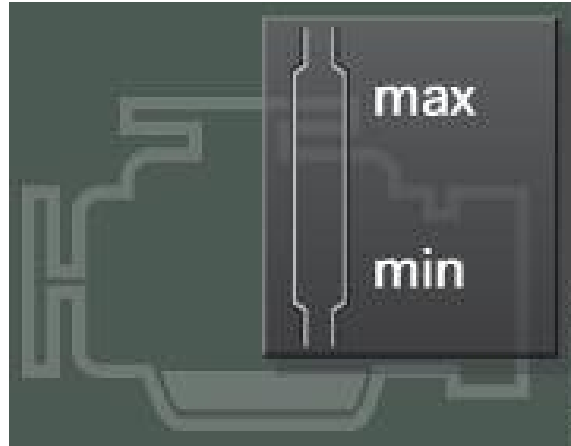

Dynamic oil level measurement begins when following values are reached:

- Engine temperature $> 60^{\circ}\text{C}$
- Engine speed > 1000 rpm
- Transverse and longitudinal acceleration $< 4\text{-}5$ m/s²

The transverse acceleration signal is supplied by the DSC. The longitudinal acceleration is calculated from the speed and time factors.

- Increase $< 5\%$ after covering a distance of app.. 200 m. The increase value is detected by the ambient pressure sensor in the DME.

On reaching this value, the oil level indicator is updated approximately 5 minutes after starting vehicle operation. The oil level is then continuously measured. The indicator is updated at 20 minute intervals. The "Check oil level" menu in connection with the dynamic oil level measurement is exited while driving (vehicle speed > 0) app.. 15 seconds after the oil level is displayed.

Display Options

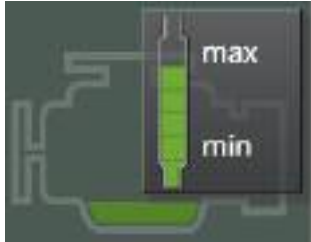
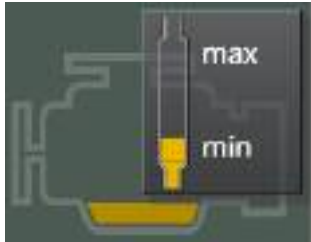
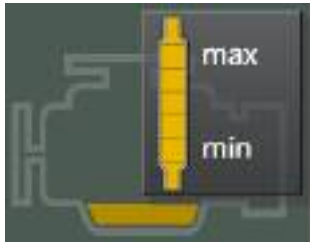
Significance	Remark	Display
Oil OK with engine stationary	The oil level appears in the CID in the form of a graphic together with the "OK" message, indicating that the oil level is in the safe operating range.	
Oil level OK at idle speed	<p>The oil level appears in the CID in the form of a graphic together with the "OK" message, indicating that the oil level is in the safe operating range.</p> <p>A further graphic showing a dipstick appears above the displayed graphic. It shows the oil level in green.</p>	
Oil level too low	<p>The oil level appears in the CID in the form of a graphic together with the request to top up with 1 liter of oil.</p> <p>If the oil is not topped up, this request is repeatedly indicated until the minimum oil level is exceeded.</p>	
Oil level too high	<p>The oil level appears in the CID in the form of a graphic together with the indication that the maximum oil level has been exceeded. The excess engine oil must be extracted in the workshop down to the maximum limit.</p> <p>If no oil is extracted, this request will be repeated until the oil level drops below the maximum limit. This represents an advantage that extends beyond the user friendliness of the monitoring system.</p> <p>Over filling of the engine that can cause leaks is indicated as a warning in the instrument cluster.</p>	
Service	There is a problem with the measurement system if SERVICE appears in the display. In this case, the oil level is forecast from the oil consumption last measured and shown in the display. It is not necessary to immediately visit a workshop. The remaining kilometers are shown in the service menu. In the event of the instrument cluster failing, the oil level can also be read out with the diagnosis tester.	

Cooling System

On most engine systems to date, the delivery capacity of the coolant pump has been designed with the greatest possible cooling requirement of the engine. In the majority of cases, this large volume of coolant is not required.

As a result, the excess coolant will circulate through the thermostat in a small circuit. The new design of the cooling system utilizes an electric coolant pump which minimizes engine power losses and allows for increased fuel economy by a more efficient method of engine heat management.

Heat Management

The engine control unit controls the coolant pump according to requirements: low output in connection with low cooling requirements and low outside temperatures; high output in connection with high cooling requirements and high outside temperatures.

The coolant pump may also be completely switched off under certain circumstances, e.g. to allow the coolant to heat up rapidly during the warm-up phase. However, this only occurs when no heating is required and the outside temperature is within the permitted range.

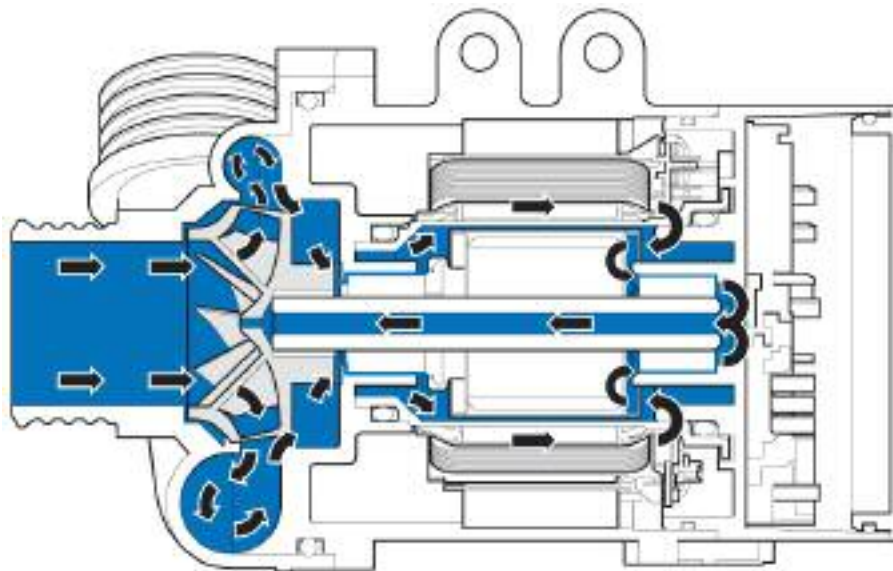

The coolant pump also operates differently than conventional pumps when controlling the engine temperature. To date, only the currently applied temperature could be controlled by the thermostat. The software in the engine control unit now features a calculation model that can take into account the development of the cylinder head temperature based on load.

In addition to the characteristic map control of the thermostat, the heat management system makes it possible to use various maps for the purpose of controlling the coolant pump. For instance, the engine control unit can adapt the engine temperature to match the current driving situation.

This means that four different temperature ranges can be implemented:

- 112°C ECO mode (economy)
- 105°C Normal mode
- 95°C High mode
- 80°C High + mapped thermostat mode

The coolant control sets a higher cylinder head temperature (112°C) if the engine control unit determines ECO mode based on the current operating conditions.

The engine is operated with relatively low fuel consumption in this temperature range as the internal friction is reduced.

An increase in temperature therefore favors lower fuel consumption in the low load range. In HIGH and mapped thermostat mode, the driver wishes to utilize the optimum power development of the engine. The cylinder head temperature is therefore reduced to 80° C.

This results in improved volumetric efficiency, thus increasing the engine torque. The engine control unit can therefore set a certain operating mode adapted to the respective driving situation. Consequently, it is possible to influence fuel consumption and power output by means of the cooling system.

Intelligent Heat Management

This concept of intelligent heat management opens up potentials for engine functions and the vehicle operator. The previous section dealt with the various operating modes in connection with heat management. However, an electrically driven coolant pump makes available even further options. For instance, it is now possible to warm up the engine without the recirculating the coolant or to allow the pump to continue to operate after turning off the engine to facilitate heat dissipation.

The advantage offered by this type of pump are listed in the following table:

Fuel Consumption	<ul style="list-style-type: none"> • Faster warm-up as coolant is not recirculated (stationary) • Increased compression ratio through greater cooling capacity at full load compared to the predecessor engine
Emissions	<ul style="list-style-type: none"> • Faster engine warmup by drastically reduced pump speed and the resulting lower volumetric flow of coolant. • Reduced friction • Reduced fuel consumption • Reduced exhaust emissions
Power output	<ul style="list-style-type: none"> • Component cooling independent of engine speed • Requirement-controlled coolant pump output • Avoidance of power loss
Comfort	<ul style="list-style-type: none"> • Optimum volumetric flow <ul style="list-style-type: none"> - Heating capacity increased as required - Residual heat with engine stationary
Component Protection	<ul style="list-style-type: none"> • EWP pump run-on after engine shutoff = more effective heat dissipation from the hot engine

Cooling System Comparison (Belt Driven vs. Electric Coolant Pump)

The belt driven coolant pump circulates the coolant as a function of engine speed. The circulated coolant can only be influenced by the mapped thermostat for temperature control purposes.

The system switches between the small and large circuit. In other words, between the circuit which flows through the radiator (large circuit) and the circuit which flows only between the engine block, coolant pump and thermostat.

This means that the cooling capacity is dependent upon engine speed.

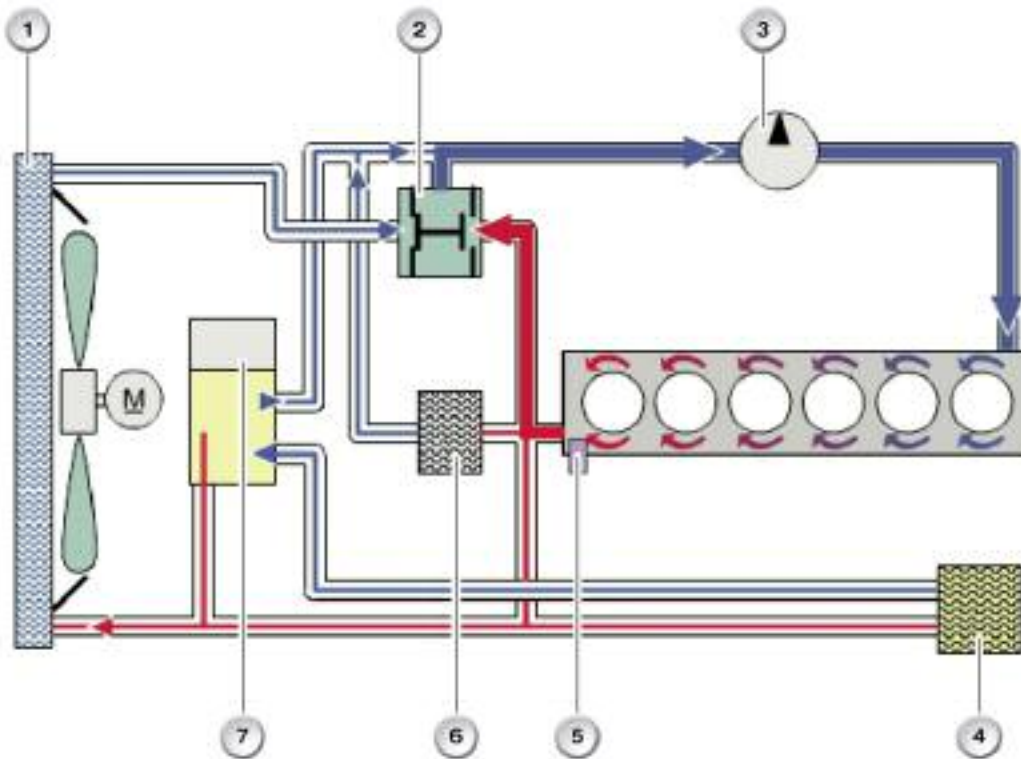

Index	Explanation	Index	Explanation
1	Radiator	5	Outlet temp sensor, cylinder head
2	Mapped Thermostat (KFT)	6	Engine oil to water heat exchanger
3	Belt driven coolant pump	7	Expansion tank
4	Heat exchanger for heating system		

The advantages of the conventional cooling system are still utilized in the cooling system with the electric coolant pump. However this system also provides further options.

For instance, the cooling capacity of the system can now be adapted by means of freely variable volumetric coolant flow. It is possible to deactivate the coolant pump while the engine is warming up or to allow it to continue to operate when the engine has been turned off.

As illustrated in the following graphic, this results in the field in which the speed related to the cooling capacity can be controlled independently. This field is limited by the MAX and MIN speed of the coolant pump.

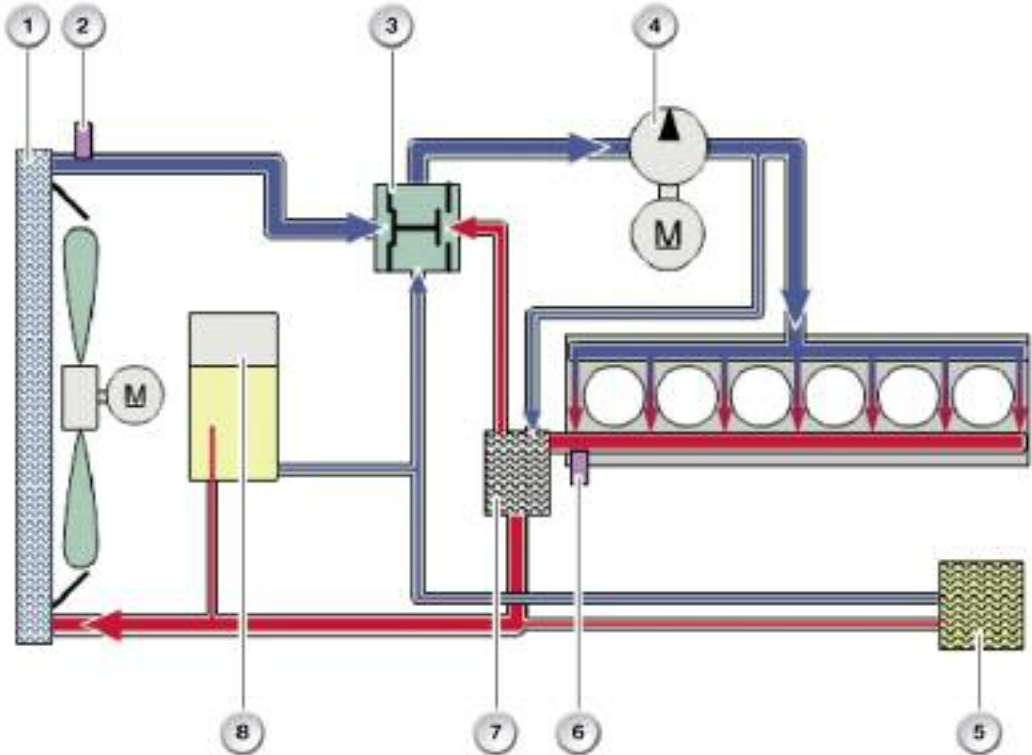

Index	Explanation	Index	Explanation
1	Radiator	5	Heat exchanger for heating system
2	Outlet temperature sensor, radiator	6	Outlet temp sensor, cylinder head
3	Mapped Thermostat (KFT)	7	Engine oil to water heat exchanger (MOWWT)
4	Electric coolant pump		Expansion tank

Note: Due to the design of this coolant pump, a special filling and bleeding procedure is implemented for service. Refer to the “Workshop Hints” section in this training module for more detailed information. Also refer to the relevant repair instructions in group 17. Refer to WebTIS for the most updated version of the repair manual.

Workshop Hints

Electronically Controlled Coolant Pump

Particular care must be taken when performing servicing work to ensure that the pump does not run dry. When the pump is removed, it should be stored filled with coolant. The bearing points of the pump could seize if the pump were not filled with coolant.

This could jeopardize subsequent start-up of the pump thus rendering the entire heat management system inoperative (the pump not starting up could cause serious engine damage). If the pump should ever run dry, the pump wheel should be turned by hand before finally connecting the coolant hoses. The system should then be immediately filled with coolant.

Particular care must be taken during assembly to ensure that the connector is clean and dry and the connections are undamaged.

Diagnosis should be performed only with the approved adapter cables. The information provided in the repair instructions must be observed. Due to this coolant pump, a special filling and bleeding procedure must be implemented for servicing:

1. Fill system with coolant via the expansion tank (AGB). Top up coolant level to lower edge of expansion tank.
2. Close expansion tank.
3. Switch on ignition.
4. Set heating to maximum (temperature), switch on blower (lowest stage).
5. Press accelerator pedal module to floor for at least 10 seconds. The engine must NOT be started.
6. Bleeding via EWP takes app.. 12 minutes. Then check coolant level in expansion tank, top up to MAX marking if necessary.
7. Check cooling circuit and drain plugs for leaks.
8. If the procedure needs to be repeated several times, allow DME to completely de-energize (remove ignition key for app.. 3 minutes) and then repeat procedure as from item 3.

Note: Connect battery charger if battery charge level is low.

Thread Repair

When repairing threads on magnesium or aluminum components, the repair instructions recommend the use of Helicoil™ repair kits. These kits are available with aluminum repair thread inserts which are available through BMW parts.

Engine Repairs

Any engine repair which involves the replacement/removal of the cylinder head requires special attention. The bolt holes must be blown dry immediately after cylinder head removal. It is not acceptable to wait until the engine is ready for reassembly. Leaving the coolant standing in the head bolt holes until reassembly will increase the possibility of contact corrosion. Engine coolant should not come into prolonged contact with magnesium engine components.

Note: Be sure to wear approved eye protection when using compressed air to dry the bolt holes.



Working Safety

Machining (metal cutting) Magnesium

The jobs that are most frequently carried out in connection with this material as part of servicing applications are considered to be non-critical. The small amount of metal chips that occurs, e.g. when recutting threads, requires no special extraction systems or special facilities.

If, on the other hand, extensive machining is to be performed on magnesium crankcases, particular care must be taken to ensure that no explosive hydrogen can collect in the collection containers for metal chips and moisture can escape from the container.

Moisture in this context only refers to water or compounds containing water. The following information must be observed for metal removing machining processes:

Although with regard to metal removal or machining properties magnesium alloys offer very good prerequisites for dry machining, today wet machining processes are state-of-the-art, involving the use of either cutting oil or emulsion. The greatest hazard potential in metal removal machining processes is posed by the metal chips (swarf). Particularly wet or moist metal chips are hazardous while, on the other hand, metal chips moistened in oil will not ignite easily.

Magnesium and water can react to form magnesium hydroxide and hydrogen. For this reason, there is a risk of a hydrogen explosion in machining processes involving emulsion if the hydrogen that is constantly formed can collect and reach a critical concentration. For this reason, it is important to ensure that the moisture in the collection container can escape or drain off.

In addition, metal chips and swarf must be conveyed at a very fast rate out of the emulsion otherwise a saponification or hardening process may occur making the emulsion unusable.

The range of cutting materials known from aluminum machining processes can also be used for magnesium machining, i.e. high speed steel, hard alloy or carbide and polycrystalline diamond (PCD).

Special Measures for Grinding

The preconditions for wet machining in grinding processes are to be considered from different aspects than the standard metal cutting machining processes. This is due to the fact that fine metal chips (grinding dust) are produced in grinding processes. As from a certain mixing ratio with air, this grinding dust can combust explosively following possible ignition from spark created from grinding or welding work. If wet grinding is not possible or too inconvenient, the grinding dust produced must be extracted and precipitated with water in a separator.

Important Precondition:

Any work on magnesium that forms dust must not be performed without a suitable extraction facility.

The specific surface of the respective product, i.e. the surface-to-volume ratio represents an important criterion for the hazard potential of the magnesium. Solid components pose no problems from a safety point of view. Even when subjected to high temperatures for all intents and purposes they cannot combust.

On the other hand, chips, particles and powder are considerably more reactive. The critical temperature at which dry, fine metal chips can ignite is at 450 - 500°C. Cutting tools that have improper edge geometries or blunt edges can give rise to such temperature levels during dry machining processes. Sparks caused by tool collisions or when machining steel represents a further source of danger. If, despite all precautionary measures, a magnesium fire occurs, on no account must water or extinguishing agents containing water be used (release of hydrogen, detonating gas explosion!). ABS powder extinguisher, carbon dioxide and nitrogen are also unsuitable as extinguishing agents.

Keep suitable metal fire extinguisher ready at hand! The proper classification for a fire extinguisher capable of handling magnesium fire is Class D. **DO NOT** use class A, B or C fire extinguishers in magnesium fires. This could create a more hazardous situation.



Classroom Exercise - Review Questions

1. Where are aluminum bolts used on the N52 and how are they identified?

2. What type of cylinder bore structure is used on the N52? What is allowable regarding cylinder bore repairs?

3. What precautions must be taken when machining magnesium?

4. What precautions must be taken when performing engine repairs that involve removal of the water pump?

5. Describe the cooling system bleeding procedures on vehicles with the N52:



Classroom Exercise - Review Questions

6. Describe the methods used to check the oil level on an N52 engine:

7. Which engine components are made from magnesium?

8. What is special about the camshafts on the N52?

9. What precautions must be taken when removing the cylinder head?

10. What special service procedures should be observed regarding aluminum bolts during service operations?
